

**SM-8213**  
**SM-8215**  
**SM-8220**

**HIOKI**

Instruction Manual

# **SUPER MEGOHMMETER**

Feb. 2019 Revised edition 6  
SM8213A981-06 19-02H

Call us : 400-806-2189

**EN**



# 日图简介

深圳市日图科技有限公司（简称“日图科技”）创立于2004年，核心业务是为国内企业提供测试设备及相关器材的供应服务，公司客户涵盖制造、科研、教育、电力、能源、通信等众多领域。创业至今，日图科技已经成为国内仪器仪表行业中最大的综合服务供应商之一，日图科技作为行内的领先者，有着高效的供应服务体系，并拥有一支专业的、高素质的服务团队。

目前，日图科技已在深圳、上海、广州、苏州、重庆、杭州、西安、香港等国内电子工业发达地区设立了办事与服务机构，并通过日图科技在全国各地的经销网络，为广大客户提供优质的本地化服务。

日图科技一贯秉承“专业、规范、诚信立业，日日图新”的宗旨，并在实践中不断提升公司的服务能力，为客户提供专业、高效、全面、经济的优质供应服务，顾客满意是日图科技永远追求的目标。

# 合作伙伴



# 优势服务

- (1) 产品选型
- (2) 测试解决方案
- (3) 免费测试服务
- (4) 代办计量校准
- (5) 维修维护
- (6) 技术培训
- (7) 物流配送
- (8) 常备应急库存

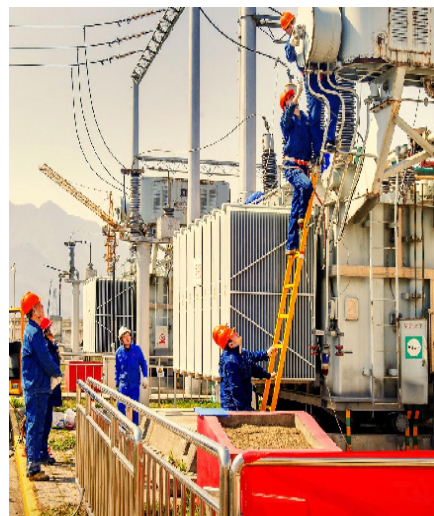

The super megohmmeter is a unique resistance meter designed to measure highresistance in a wide range. The meter outputs a high test voltage – 1000 V maximum for the SM-8220/8215, and 100 V maximum for the SM-8213 – to apply across the sample circuit.

Operators are requested to read this operation manual thoroughly before trying to operate the instrument for safety and to prevent electrical shock and damage to the measured circuit.

Keep this manual where all staff can access it any time.

## 1. Safety Precautions

Operators of the SM-8200 Series super megohmmeter are requested to read this operation manual thoroughly before operation for safety and to obtain best performance.

Operators are also requested to strictly observe all the DANGER, WARNING, and CAUTION notices in this manual and on the instrument to prevent injury and damage.

### 1-1 Safety Warnings

This operation manual includes some DANGER!, WARNING!, and CAUTION! notice with a symbol. These must be observed for safety of the operator and other persons, as well as for protection of your super megohmmeter and samples from possible damage and destruction.



#### **DANGER**

A “DANGER” CALLS ATTENTION TO A CONDITION OR POSSIBLE SITUATION THAT CAN CAUSE DEATH OR INJURY TO THE OPERATOR OR NEAR PESONS.



#### **WARNING**



A “WARNING” CALLS ATTENTION TO A CONDITION OR POSSIBLE SITUATION THAT COULD CAUSE DEATH OR INJURY TO THE OPERATOR OR NEAR PESONS.



#### **CAUTION**

A “CAUTION” calls attention to a condition or possible situation that could cause injury to the operator or persons nearby and damage and destroy the super megohmmeter and samples.

## 1.2 Symbols on the Super Megohmmeter

Symbol	Meaning	Description
	WARNING	This symbol is shown at parts whose usage needs reference to the operation manual.
	DANGER – HIGH VOLTAGE HAZARD	This symbol is shown at the Rx “-/+” Measuring terminals which carry a high voltage to be applied across the circuit to be measured.
		This symbol is shown at the GND terminal on the rear of the unit. If the ground prong of the power cord plug cannot be grounded, this terminal must be connected to the ground.

### Safety Warning Labels on the Super Megohmmeter

#### 1) DANGER and WARNING Labels on the Housing and Front Panel

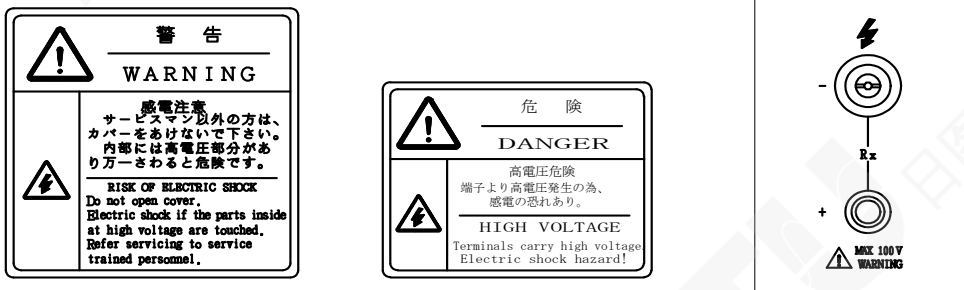

#### 2) DANGER and WARNING Labels on the Rear Panel

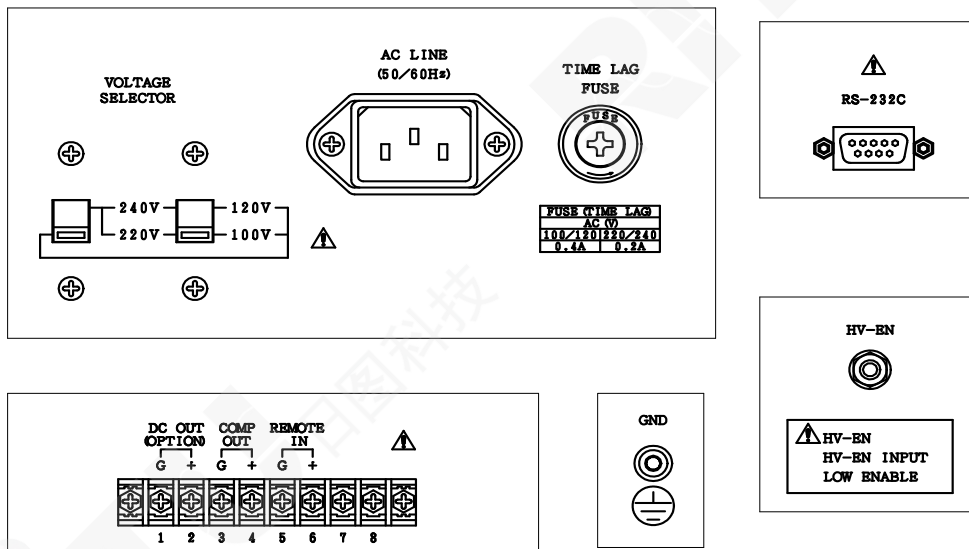

## 2. Operating Environmental Precautions



### **DANGER**

- Do not operate the super megohmmeters in the presence of flammable gas. There is a possibility of an explosion and/or fire.
- Do not touch the Rx “-”/“+” measuring terminals on the front panel of the instrument during measurement. They output a maximum of 1000 V (SM-8220/8215) or 100 V (SM-8213) for measurement.



### **WARNING**

- Ground the ground prong of the power cord plug to avoid electrical shock. If the ground prong cannot be grounded, connect the GND terminal on the rear of the instrument to a ground. When the power cord plug is connected to the AC line socket via an accessory 3-prong to 2-prong adapter, the green ground tab of the adapter to the ground.
- Do not remove the housing cover of the instrument. Even after turning off the instrument power switch, a dangerous residual voltage may be present for several minutes after the power is turned off. If repair or internal readjustment is needed, contact your dealer or Hioki representative.
- To avoid electric shock, do not exceed the lower of the ratings shown on the instrument and test leads.



### **CAUTION**

- Before turning on the power switch for the instrument, check that the VOLTAGE SELECTOR switches are set for your local AC line voltage. If the wrong AC line voltage is applied to the unit, it will be damaged (higher voltage supply) or will not function properly (lower voltage supply).  
See 1.3 Setting VOLTAGE SELECTOR Switches for setting.  
Use the right size and amperage power fuse. If a fuse of incorrect amperage is inserted into the fuse holder, the unit will be damaged.  
See 1.4 Checking the Fuse Amperage for a correct fuse amperage.
- Do not install or operate the super megohmmeter on a surface which is not level or not stable.

### 3. Installation Precaution



#### **CAUTION**

Do not install or place the super megohmmeter in a location which is not level, not stable or not sturdy enough to hold the instrument and other related items.

### 4. Instrument Handling Precautions



#### **WARNING**

- If the instrument generates smoke or smell, unplug the power cord.  
If such an instrument is kept powered on, it may cause a fire.  
contact your dealer or Hioki representative for repair.
- Do not operate the instrument with a wet hand. This may cause electrical shock.



#### **CAUTION**

- When moving or transporting the super megohmmeter, avoid shock and vibration as much as possible. For long-distance transportation, put the instrument in a shock-absorbing carton or use the original shipping carton.
- When not using the super megohmmeter for an extended period of time, unplug the power cord from the AC line socket. Put a dust cover on the instrument. Store it in a place free of corrosive gas and vibration, with a surrounding temperature within the range from  $-5$  to  $45^{\circ}\text{C}$ , and humidity 80% RH or less(non-condensating).
- Do not place anything on the instrument.

## **BRIEF DESCRIPTION**

### **About the SM-8200 Series Super Megohmmeters**

The SM-8200 Series super megohmmeters are insulation resistance meters consisting of a constant voltage power supply and a high sensitive current measuring section. The super megohmmeters are designed to measure the electrical resistance of insulating materials with high insulation properties.

The resistance measuring ranges of the SM-8200 Series are as follows:

SM-8213:  $2.5 \times 10^4$  to  $2 \times 10^{12} \Omega$

SM-8215:  $2.5 \times 10^5$  to  $2 \times 10^{13} \Omega$

SM-8220:  $5.0 \times 10^4$  to  $2 \times 10^{16} \Omega$

Each model of the super megohmmeters is provided with an LCD  $320 \times 240$  dot display for easy observation of necessary information, including measuring voltage, measured resistance in both digital and analog, timer, and resultant GO/NO judgment.

The following shows the main specifications for the super megohmmeters.

For detailed specifications, see 2. SPECIFICATIONS.

For optional accessories, see 9. OPTIONAL ACCESSORIES.

### **Main Specifications – For detailed specifications, see 2. SPECIFICATIONS.**

**For optional accessories, see 9. OPTIONAL ACCESSORIES.**

Measuring Voltage Ranges:

SM-8213 – 5, 10, 15, 25, 50 and 100 V

SM-8215 – 50, 100, 250, 500 and 1000 V

SM-8220 – 10, 25, 50, 100, 250, 500 and 1000 V

Measuring Resistance Range:

SM-8213:  $2.5 \times 10^4$  to  $2 \times 10^{12} \Omega$

SM-8215:  $2.5 \times 10^5$  to  $2 \times 10^{13} \Omega$

SM-8220:  $5.0 \times 10^4$  to  $2 \times 10^{16} \Omega$

Timer Function: Provided

Comparison and Judgment Function: Provided

HV-EN (High Voltage Enable) Interlocking Function: Provided

Voltage Charging Function: Provided

Voltage Discharging Function: Provided

RS-232C Interface Connector: Provided

Remote Measurement Function: Provided



## **Organization of This Operation Manual**

This operation manual contains the following 10 sections.

### **1. PREPARATION BEFORE OPERATION**

This section describes precautions for unpacking and AC line voltage setting.

### **2. SPECIFICATIONS**

This section describes the specifications for the SM-8200 Series super megohmmeters and optional accessories.

### **3. OPERATING PRINCIPLE**

This section describes the operating principle with a block diagram of the SM-8200 Series.

### **4. FAMILIARIZATION WITH CONTROLS AND PARTS**

This section describes the functions of the controls and parts on the front and rear panels.

### **5. PREPARATION FOR MEASUREMENT**

This section describes the LCD display in detail for the measuring mode, setting mode and operations. A variety of measured value display methods are also given.

### **6. MEASUREMENT**

This section provides details for function setting, connection to the work to be measured, and usage of a variety of optional measuring jigs and electrodes.

### **7. RS-232C INTERFACE**

This section describes the application of the serial port interface.

### **8. REMOTELY CONTROLLED MEASUREMENT**

This section describes the remote measuring function.

### **9. INTRODUCTION OF OPTIONALS**

This section describes the optional accessories, including guard chips, DC signal outputs, and others.

### **10. MAINTENANCE AND MISCELANEOUS**

This section describes maintenance and calibration.

### **11. EXTERNAL APPEARANCE**

This section includes front, rear and side view illustrations of the instrument with dimensions.



# CONTENTS

<b>1. PREPARATION BEFORE OPERATION</b> . . . . .	1
<b>1.1 Unpacking and Checking of the Contents</b> . . . . .	1
<b>1.2 Operating AC Line Voltage</b> . . . . .	2
<b>1.3 Setting the VOLTAGE SELECTOR Switches</b> . . . . .	2
<b>1.4 Checking the Fuse Amperage.</b> . . . . .	3
<b>1.5 Grounding the Chassis</b> . . . . .	4
<b>1.6 Warm-up Period</b> . . . . .	5
<b>2. SPECIFICATIONS</b> . . . . .	6
<b>2.1 Measuring Performance</b> . . . . .	6
<b>2.2 Function Specifications</b> . . . . .	7
<b>2.3 Other Electrical and Physical Data</b> . . . . .	8
<b>2.4 Optional Functions and Accessories</b> . . . . .	8
<b>2.5 List of Measurement Ranges and Guaranteed Accuracy Ranges by Model.</b> . . . . .	9
<b>3. OPERATING PRINCIPLE</b> . . . . .	1 2
<b>4. FAMILIARIZATION WITH CONTROLS AND PARTS</b> . . . . .	1 3
<b>4.1 Front Panel</b> . . . . .	1 3
<b>4.2 Rear Panel</b> . . . . .	1 5
<b>4.3 Measuring Display</b> . . . . .	1 7
<b>4.4 Measuring Condition Setting Display</b> . . . . .	1 8
<b>4.5 Meanings of the Status and Mode Notices.</b> . . . . .	1 9
<b>5. PREPARATION FOR A MEASUREMENT</b> . . . . .	2 0
<b>5.1 Preparation.</b> . . . . .	2 0
<b>5.2 Self-calibration 1.</b> . . . . .	2 1
<b>5.3 Self-calibration 2.</b> . . . . .	2 1
<b>5.4 Check the Measuring Rods</b> . . . . .	2 2
<b>5.5 Basic Procedures for a Measurement.</b> . . . . .	2 3
<b>6. MEASUREMENT.</b> . . . . .	2 4
<b>6.1 Measuring Method.</b> . . . . .	2 4
<b>6.2 Discharging Function</b> . . . . .	2 5
<b>6.3 Charging Function</b> . . . . .	2 5
<b>6.4 Interlocking Function – Using the HV-EN Connector</b> . . . . .	2 6
<b>6.5 Comparison and Judgment Function</b> . . . . .	2 7

<b>6.6 Setting a Variety of Functions . . . . .</b>	<b>2 8</b>
<b>6.6.1 Setting the Timer . . . . .</b>	<b>2 8</b>
<b>6.6.2 Setting the Comparison GO/NO Judgment Level . . . . .</b>	<b>2 8</b>
<b>6.6.3 Setting Buzzer Sound ON/OFF . . . . .</b>	<b>2 9</b>
<b>6.6.4 Setting the Charging Time, Measuring Time, Comparison GO/NO Judging Level and Buzzer Sound ON/OFF. . . . .</b>	<b>2 9</b>
<b>6.7 Changes in the Current Flowing through Insulators. . . . .</b>	<b>3 1</b>
<b>6.8 Connectivity Precautions. . . . .</b>	<b>3 2</b>
<b>6.8.1 When the Screen Shows LOCK and Measurement Cannot Be Started . . .</b>	<b>3 2</b>
<b>6.8.2 When Using an Optional Electrode for Plate Samples or Shield Box . .</b>	<b>3 3</b>
<b>7. RS-232C INTERFACE . . . . .</b>	<b>3 4</b>
<b>7.1 RS-232C Communication Commands . . . . .</b>	<b>3 4</b>
<b>7.2 Applications of Commands . . . . .</b>	<b>3 5</b>
<b>7.3 Connector Specifications. . . . .</b>	<b>3 5</b>
<b>7.4 Printer Output . . . . .</b>	<b>3 6</b>
<b>8. REMOTELY CONTROLLED MEASUREMENT . . . . .</b>	<b>3 7</b>
<b>9. INTRODUCTION OF OPTIONS . . . . .</b>	<b>4 0</b>
<b>9.1 DC Signal Outputs. . . . .</b>	<b>4 0</b>
<b>9.1.1 DC Output, RP-8000</b>	
<b>- Directly proportional or linear to resistance . . . . .</b>	<b>4 0</b>
<b>9.1.2 DC Output, RI-8000</b>	
<b>- Inversely proportional or 1/R to resistance . . . . .</b>	<b>4 2</b>
<b>10. MAINTENANCE AND MISCELANEOUS . . . . .</b>	<b>4 5</b>
<b>10.1 Periodical Checking . . . . .</b>	<b>4 5</b>
<b>10.2 Storage, Transportation and Abandon . . . . .</b>	<b>4 5</b>
<b>11. EXTERNAL APPEARANCE . . . . .</b>	<b>4 6</b>

## 1. PREPARATION BEFORE OPERATION

### 1.1 Unpacking and Checking of the Contents

When you have received the carton of the SM-8200 Series super megohmmeter, carefully unpack it, and take out every thing from the carton.

Although the instrument and its accessories are severely inspected before shipment from factory, visually check the items and their quantities.

Keep the shipping carton for reuse at a later stage.

- 1) Visually check the external view of the instrument and its accessories.
- 2) Check the quantities of the list in accordance with the following list:

Table 1.1 List of Standard Accessories

Item	Model No.	Q'ty	Remarks
Operation manual	—	1	This item means this booklet.
Power cord	—	1	Power cord with 3-prong plug with third for grounding
Measuring rod (Red)	OGE00002	1	A measuring rod with a 1-meter cord to be connected to the Rx '-' socket.
Measuring rod (Black)	OGE00001	1	A measuring rod with a 1-meter cord to be connected to the Rx '+' socket.
Shorting plug	OGZ00003	1	A plug to be plugged to the HV-EN socket of the rear of the instrument. It is plugged to the HV-EN socket when shipping from factory.

#### **Important!**

When the accessory shorting plug is not plugged to the HV-EN socket on the rear of the instrument, the measuring high voltage is not output.

Note: The shorting plug is plugged to the HV-EN socket when shipping from factory.

 <b>CAUTION</b> When plugging the shorting plug, make sure that the power is turned off, otherwise, there is an electric shock hazard.
--

Upon checking the instrument and accessories, if any damage is found, immediately contact your dealer or Hioki representative.

## 1.2 Operating AC Line Voltage

The super megohmmeter can be operated from one of the following AC power source when the VOLTAGE SELECTOR switches are set accordingly.

<u>AC Line Voltage</u>	<u>Frequency</u>
100 V $\pm$ 10%	50/60 Hz
120 V $\pm$ 10%	50/60 Hz
220 V $\pm$ 10%	50/60 Hz
240 V +10V, -10%	50/60 Hz



### CAUTION

Before connecting the power cord to the AC outlet socket, confirm that the VOLTAGE SELECTOR switches on the rear panel are set to the positions, accordingly (See 1.3 Setting the VOLTAGE SELECTOR Switches.).

If the switches are set to wrong positions, a fire or burn may occur.

## 1.3 Setting VOLTAGE SELECTOR Switches

The super megohmmeter can be operated from one of the AC line voltages of 100 V, 120 V, 220 V and 240 V by setting the VOLTAGE SELECTOR switches to the specific positions, respectively.

Confirm the switch setting to the specific positions in accordance with Fig. 1.1.

If they are not set properly, correct their positions, accordingly.

To change the position of the switch, insert the tip of a flat blade screwdriver into the slot of the switch lever, and slide the lever upward or downward.



### CAUTION

To change the VOLTASGE SELECTOR switch positions, be sure to unplug the power cord plug from the AC line socket to prevent a possible damage.

When the switch position is changed while the voltage is on, the Switch contacts will be damaged.

**CAUTION**

The VOLTAGE SELECTOR switches have two positions – up and down. Slide the switch lever to either position until it stops.

Do not leave the lever at a neutral position. If the lever is set at a neutral position, a normal function cannot be obtained, and it will cause a failure.

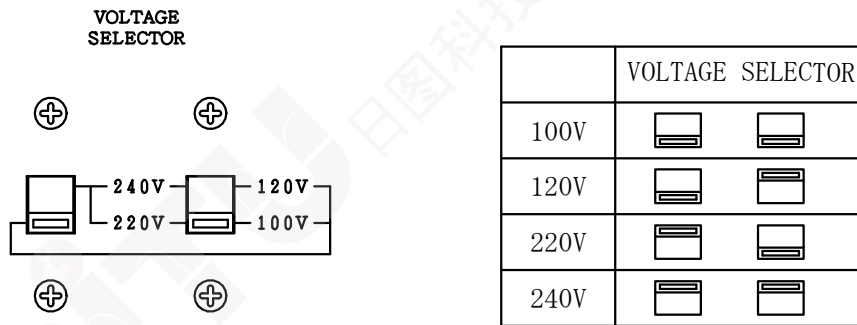

Fig. 1.1 VOLTAGE SELECTOR Switch Setting

**CAUTION**

When the VOLTAGE SELECTOR switch position is changed, fuse amperage must be changed to meet the requirements of the new AC line voltage.

Incorrect fuse amperage will cause a failure of the instrument.

#### 1.4 Checking the Fuse Amperage

The fuse holder of the instrument contains a time lag fuse of the following amperage:

Time Lag Fuse	
<u>AC Line Voltage</u>	<u>Fuse Amperage</u>
100 V/120 V	0.4 A
220 V/240 V	0.2 A

## Fuse Replacement

The fuse is inserted in the FUSE holder (Fig. 1.2) on the rear of the unit.

Remove the cap, and replace the fuse with a new one with a correct amperage.

To remove the cap of the fuse holder, use a 4 mm Phillips screwdriver, and turn the cap counterclockwise.

To set the cap in position, insert the cap, holding the fuse into the holder, and turn it with the screwdriver.

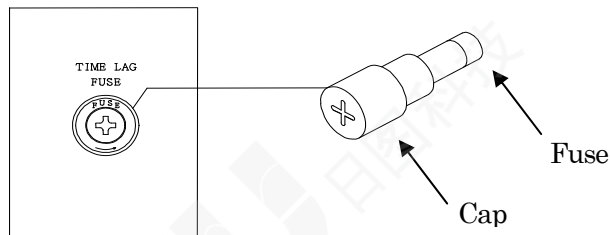

Fig. 1.2 Fuse Holder and Fuse Replacement



### **WARNING**

To replace or check the fuse, make sure to disconnect the power cord from the AC line socket. If not, there is a fear of electrical shock.

## 1.5 Grounding the Chassis

To avoid an electrical shock accident, connect the GND terminal on the rear of the unit to the ground prong of the power cord to the ground post of the AC line system.

The round prong of the 3-prong plug of the power cord is the ground prong.

It is recommended to use an AC line socket with its third contact grounded for connection of the accessory 3-prong power cord.

To use the accessory 3-prong to 2-prong adapter to connect the power cord to a 2-contact AC line socket, make sure to ground the green tab of the adapter.



### **WARNING**

To prevent an accident, connect the ground prong of the power cord Plug to the ground post of the AC line system. If it is impossible to ground the ground prong of the power cord plug, be sure to connect the GND terminal on the rear of the unit.



## **1.6 Warm-up Period**

To obtain the performance of published specifications, allow the SM-8200 Series super megohmmeter to warm for a minimum of 30 minutes.

## 2. SPECIFICATIONS

### 2.1 Measuring Performance

#### 1) Electrical Resistance Measurement

**SM-8213(RANGE :  $\times 1$  ,  $\times 10$  ,  $\times 10^2$  ,  $\times 10^3$  ,  $\times 10^4$  , or  $\times 10^5$ )**

Measurement Range (M $\Omega$ ) [RANGE= $\times 10^R$ ]	Target Voltage
0.5 $\times 10^R$ to 20 $\times 10^R$	100 V
0.25 $\times 10^R$ to 10 $\times 10^R$	50 V
0.125 $\times 10^R$ to 5 $\times 10^R$	25 V
0.075 $\times 10^R$ to 3 $\times 10^R$	15 V
0.05 $\times 10^R$ to 2 $\times 10^R$	10 V
0.025 $\times 10^R$ to 1 $\times 10^R$	5 V

Accuracy of target voltage:  $\pm 3\%$  of set value

Measuring output current: 50 mA maximum (Note: 1)

Accuracy of measurement:  $\pm 10\%$  (A range of 10 times of the minimum value of each range) (Note: 2)

**SM-8215(RANGE :  $\times 1$  ,  $\times 10$  ,  $\times 10^2$  ,  $\times 10^3$  ,  $\times 10^4$  , or  $\times 10^5$ )**

Measurement Range (M $\Omega$ ) [RANGE= $\times 10^R$ ]	Target Voltage
5 $\times 10^R$ to 200 $\times 10^R$	1000 V
2.5 $\times 10^R$ to 100 $\times 10^R$	500 V
1.25 $\times 10^R$ to 50 $\times 10^R$	250 V
0.5 $\times 10^R$ to 20 $\times 10^R$	100 V
0.25 $\times 10^R$ to 10 $\times 10^R$	50 V

Accuracy of target voltage:  $\pm 3\%$  of set value

Measuring output current: 2 mA maximum (Note: 1)

Accuracy of measurement:  $\pm 10\%$  (A range of 10 times of the minimum value of each range) (Note: 2)

**SM-8220(RANGE :  $\times 1$  ,  $\times 10$  ,  $\times 10^2$  ,  $\times 10^3$  ,  $\times 10^4$  ,  $\times 10^5$  ,  $\times 10^6$  ,  $\times 10^7$  , or  $\times 10^8$ )**

Measurement Range (M $\Omega$ ) [RANGE= $\times 10^R$ ]	Target Voltage
5 $\times 10^R$ to 200 $\times 10^R$	1000 V
2.5 $\times 10^R$ to 100 $\times 10^R$	500 V
1.25 $\times 10^R$ to 50 $\times 10^R$	250 V
0.5 $\times 10^R$ to 20 $\times 10^R$	100 V
0.25 $\times 10^R$ to 10 $\times 10^R$	50 V
0.125 $\times 10^R$ to 5 $\times 10^R$	25 V
0.05 $\times 10^R$ to 2 $\times 10^R$	10 V

Accuracy of target voltage:  $\pm 3\%$  of set value

Measuring output current: 2 mA maximum (Note: 1)

Accuracy of measurement:  $\pm 10\%$  (A range of 10 times of the minimum value of each range) except for  $\times 10^8$  range. (Note: 2)  
 $\pm 20\%$  for  $\times 10^8$  range

Note 1: The measurement output current may reach as high as approximately 1.4 times the maximum value. When a current in excess of the measurement output current's maximum value is output, the set measurement voltage may drop.

Note 2: The measurement accuracy is defined as  $\pm 10\%$  of the indicated measured value displayed on the screen.

2) Measuring Time (Sampling Cycle)

Approx. 200 ms

## 2.2 Function Specifications

1) CHARGE Function

This function charges the sample to be measured by applying the Selected measuring voltage when the CHARGE switch is pushed.

Internal Resistance

SM-8213: Approx.  $0\ \Omega$

SM-8215: Approx.  $30\text{k}\Omega$

SM-8220: Approx.  $30\text{k}\Omega$

2) DISCHARGE Function

This function discharges a residual voltage on the sample after measurement when the DISCHARGE switch is pushed.

Internal Resistance

All models: Approx.  $100\text{k}\Omega$

3) HV-EN (High Voltage Enable) – Interlocking Function

This function externally controls to make the output of measuring voltage on or off.

This function is used in combination with an interlock switch on the measuring jig so as to prevent an electrical shock during measurement.

4) TIMER Function

This function determines the voltage charging time and the measuring time, respectively, within a range from 1 to 999 seconds. After the set time is up, the measured value is shown held.

5) COMPARISON and JUDGMENT Function

This function makes a comparison of the measured value with the preset judgment value, and if the measured value is less than the judgment level, it makes the alert buzzer sound, closing the incorporated relay contacts.

6) RS-232C Interface Function

This function allows a control of an optional printer via RS-232C interface.

The optional printer prints measured data.

7) REMOTE MEASUREMENT Function

This function allows a remotely controlled measurement by means of a remote switch.

### 2.3 Other Electrical and Physical Data

- 1) Environmental temperature and Humidity
  - Operation: 0°C to 40°C (SM-8213/8215), 80% RH or less (non-condensating)
  - 5°C to 35°C (SM-8220), 80% RH or less (non-condensating)
  - Storage: -5°C to 45°C, 80% RH or less(non-condensating)
- 2) Power Requirements
  - AC 100 V, 120 V, 220 V, ±10%, 240 V +10 V, -10% 50 Hz /60 Hz
- 3) Power Consumption
  - Approx. 25 VA
- 4) Dimensions
  - Approx. 284 (W) × 139 (H) × 215 (D) mm
  - Also, see 11. EXTERNAL VIEW for external appearance.
- 5) Weight
  - Approx. 4.3 kg
- 6) Product warranty period
  - 1 year

### 2.4 Optional Functions and Accessories

In addition to the standard accessories shown in 1.1 Unpacking and Checking of the Contents and Table 1.1 List of Standard Accessories, the following two groups of optional accessories are available to expand the applications of the SM-8200 Series super megohmmeters.

- 1) Options – designed exclusive for the SM-8200 Series

Name	Model
Printer	9442

- 2) Options – designed for common to SM-8200 Series, SM-8216, and SM-8000 Series super megohmmeters.

Name	Model	Description
Electrode for plate samples	SME-8310	With surface/volumetric selector, interlock function
Electrode for plate samples	SME-8311	
Weight electrode	SME-8320	With surface/volumetric Selector. Needs shield box.
Shield box	SME-8350	Electromagnetic shielding
Electrode for surface resistance measurement	SME-8301	Simplified electrode for surface resistance measurement
Electrode for surface resistance measurement	SME-8302	Simplified electrode for curved surface resistance measurement
Electrodes for liquid sample measurement	SME-8330	Capacity, approx. 25 mL Electrode constant: Approx. 500 cm
Surface/Volume Resistance Measurement Electrode	SM9001	Surface/volume resistance measurement of antistatic flooring, etc.
Electrodes for chip capacitors	SME-8360	Chip capacitor measurement

## 2.5 List of Measurement Ranges and Guaranteed Accuracy Ranges by Model

### SM-8213

Voltage	Range/measurement range (with guaranteed accuracy range in parentheses)[MΩ]					
	×1	×10	×10 <sup>2</sup>	×10 <sup>3</sup>	×10 <sup>4</sup>	×10 <sup>5</sup>
5V	0.025×10 <sup>0</sup> : 1.00×10 <sup>0</sup> (0.250×10 <sup>0</sup> )	0.025×10 <sup>1</sup> : 1.00×10 <sup>1</sup> (0.250×10 <sup>1</sup> )	0.025×10 <sup>2</sup> : 1.00×10 <sup>2</sup> (0.250×10 <sup>2</sup> )	0.025×10 <sup>3</sup> : 1.00×10 <sup>3</sup> (0.250×10 <sup>3</sup> )	0.025×10 <sup>4</sup> : 1.00×10 <sup>4</sup> (0.250×10 <sup>4</sup> )	0.025×10 <sup>5</sup> : 1.00×10 <sup>5</sup> (0.250×10 <sup>5</sup> )
10V	0.050×10 <sup>0</sup> : 2.00×10 <sup>0</sup> (0.500×10 <sup>0</sup> )	0.050×10 <sup>1</sup> : 2.00×10 <sup>1</sup> (0.500×10 <sup>1</sup> )	0.050×10 <sup>2</sup> : 2.00×10 <sup>2</sup> (0.500×10 <sup>2</sup> )	0.050×10 <sup>3</sup> : 2.00×10 <sup>3</sup> (0.500×10 <sup>3</sup> )	0.050×10 <sup>4</sup> : 2.00×10 <sup>4</sup> (0.500×10 <sup>4</sup> )	0.050×10 <sup>5</sup> : 2.00×10 <sup>5</sup> (0.500×10 <sup>5</sup> )
15V	0.075×10 <sup>0</sup> : 3.00×10 <sup>0</sup> (0.750×10 <sup>0</sup> )	0.075×10 <sup>1</sup> : 3.00×10 <sup>1</sup> (0.750×10 <sup>1</sup> )	0.075×10 <sup>2</sup> : 3.00×10 <sup>2</sup> (0.750×10 <sup>2</sup> )	0.075×10 <sup>3</sup> : 3.00×10 <sup>3</sup> (0.750×10 <sup>3</sup> )	0.075×10 <sup>4</sup> : 3.00×10 <sup>4</sup> (0.750×10 <sup>4</sup> )	0.075×10 <sup>5</sup> : 3.00×10 <sup>5</sup> (0.750×10 <sup>5</sup> )
25V	0.125×10 <sup>0</sup> : 5.00×10 <sup>0</sup> (1.25×10 <sup>0</sup> )	0.125×10 <sup>1</sup> : 5.00×10 <sup>1</sup> (1.25×10 <sup>1</sup> )	0.125×10 <sup>2</sup> : 5.00×10 <sup>2</sup> (1.25×10 <sup>2</sup> )	0.125×10 <sup>3</sup> : 5.00×10 <sup>3</sup> (1.25×10 <sup>3</sup> )	0.125×10 <sup>4</sup> : 5.00×10 <sup>4</sup> (1.25×10 <sup>4</sup> )	0.125×10 <sup>5</sup> : 5.00×10 <sup>5</sup> (1.25×10 <sup>5</sup> )
50V	0.250×10 <sup>0</sup> : 10.0×10 <sup>0</sup> (2.50×10 <sup>0</sup> )	0.250×10 <sup>1</sup> : 10.0×10 <sup>1</sup> (2.50×10 <sup>1</sup> )	0.250×10 <sup>2</sup> : 10.0×10 <sup>2</sup> (2.50×10 <sup>2</sup> )	0.250×10 <sup>3</sup> : 10.0×10 <sup>3</sup> (2.50×10 <sup>3</sup> )	0.250×10 <sup>4</sup> : 10.0×10 <sup>4</sup> (2.50×10 <sup>4</sup> )	0.250×10 <sup>5</sup> : 10.0×10 <sup>5</sup> (2.50×10 <sup>5</sup> )
100V	0.500×10 <sup>0</sup> : 20.0×10 <sup>0</sup> (5.00×10 <sup>0</sup> )	0.500×10 <sup>1</sup> : 20.0×10 <sup>1</sup> (5.00×10 <sup>1</sup> )	0.500×10 <sup>2</sup> : 20.0×10 <sup>2</sup> (5.00×10 <sup>2</sup> )	0.500×10 <sup>3</sup> : 20.0×10 <sup>3</sup> (5.00×10 <sup>3</sup> )	0.500×10 <sup>4</sup> : 20.0×10 <sup>4</sup> (5.00×10 <sup>4</sup> )	0.500×10 <sup>5</sup> : 20.0×10 <sup>5</sup> (5.00×10 <sup>5</sup> )

\*All resistance values are expressed in MΩ.

**SM-8215**

Voltage	Range/measurement range (with guaranteed accuracy range in parentheses) [MΩ]					
	×1	×10	×10 <sup>2</sup>	×10 <sup>3</sup>	×10 <sup>4</sup>	×10 <sup>5</sup>
50V	0.250×10 <sup>0</sup> : 10.0×10 <sup>0</sup> (2.50×10 <sup>0</sup> )	0.250×10 <sup>1</sup> : 10.0×10 <sup>1</sup> (2.50×10 <sup>1</sup> )	0.250×10 <sup>2</sup> : 10.0×10 <sup>2</sup> (2.50×10 <sup>2</sup> )	0.250×10 <sup>3</sup> : 10.0×10 <sup>3</sup> (2.50×10 <sup>3</sup> )	0.250×10 <sup>4</sup> : 10.0×10 <sup>4</sup> (2.50×10 <sup>4</sup> )	0.250×10 <sup>5</sup> : 10.0×10 <sup>5</sup> (2.50×10 <sup>5</sup> )
100V	0.500×10 <sup>0</sup> : 20.0×10 <sup>0</sup> (5.00×10 <sup>0</sup> )	0.500×10 <sup>1</sup> : 20.0×10 <sup>1</sup> (5.00×10 <sup>1</sup> )	0.500×10 <sup>2</sup> : 20.0×10 <sup>2</sup> (5.00×10 <sup>2</sup> )	0.500×10 <sup>3</sup> : 20.0×10 <sup>3</sup> (5.00×10 <sup>3</sup> )	0.500×10 <sup>4</sup> : 20.0×10 <sup>4</sup> (5.00×10 <sup>4</sup> )	0.500×10 <sup>5</sup> : 20.0×10 <sup>5</sup> (5.00×10 <sup>5</sup> )
250V	1.25×10 <sup>0</sup> : 50.0×10 <sup>0</sup> (12.5×10 <sup>0</sup> )	1.25×10 <sup>1</sup> : 50.0×10 <sup>1</sup> (12.5×10 <sup>1</sup> )	1.25×10 <sup>2</sup> : 50.0×10 <sup>2</sup> (12.5×10 <sup>2</sup> )	1.25×10 <sup>3</sup> : 50.0×10 <sup>3</sup> (12.5×10 <sup>3</sup> )	1.25×10 <sup>4</sup> : 50.0×10 <sup>4</sup> (12.5×10 <sup>4</sup> )	1.25×10 <sup>5</sup> : 50.0×10 <sup>5</sup> (12.5×10 <sup>5</sup> )
500V	2.50×10 <sup>0</sup> : 100×10 <sup>0</sup> (25.0×10 <sup>0</sup> )	2.50×10 <sup>1</sup> : 100×10 <sup>1</sup> (25.0×10 <sup>1</sup> )	2.50×10 <sup>2</sup> : 100×10 <sup>2</sup> (25.0×10 <sup>2</sup> )	2.50×10 <sup>3</sup> : 100×10 <sup>3</sup> (25.0×10 <sup>3</sup> )	2.50×10 <sup>4</sup> : 100×10 <sup>4</sup> (25.0×10 <sup>4</sup> )	2.50×10 <sup>5</sup> : 100×10 <sup>5</sup> (25.0×10 <sup>5</sup> )
1000V	5.00×10 <sup>0</sup> : 200×10 <sup>0</sup> (50.0×10 <sup>0</sup> )	5.00×10 <sup>1</sup> : 200×10 <sup>1</sup> (50.0×10 <sup>1</sup> )	5.00×10 <sup>2</sup> : 200×10 <sup>2</sup> (50.0×10 <sup>2</sup> )	5.00×10 <sup>3</sup> : 200×10 <sup>3</sup> (50.0×10 <sup>3</sup> )	5.00×10 <sup>4</sup> : 200×10 <sup>4</sup> (50.0×10 <sup>4</sup> )	5.00×10 <sup>5</sup> : 200×10 <sup>5</sup> (50.0×10 <sup>5</sup> )

\*All resistance values are expressed in MΩ.

**SM-8220**

Voltage	Range/measurement range (with guaranteed accuracy range in parentheses) Voltage [MΩ]								
	× 1	× 10	× 10 <sup>2</sup>	× 10 <sup>3</sup>	× 10 <sup>4</sup>	× 10 <sup>5</sup>	× 10 <sup>6</sup>	× 10 <sup>7</sup>	× 10 <sup>8</sup>
10V	0.050 × 10 <sup>0</sup> : 2.00 × 10 <sup>0</sup> (0.500 × 10 <sup>0</sup> )	0.050 × 10 <sup>1</sup> : 2.00 × 10 <sup>1</sup> (0.500 × 10 <sup>1</sup> )	0.050 × 10 <sup>2</sup> : 2.00 × 10 <sup>2</sup> (0.500 × 10 <sup>2</sup> )	0.050 × 10 <sup>3</sup> : 2.00 × 10 <sup>3</sup> (0.500 × 10 <sup>3</sup> )	0.050 × 10 <sup>4</sup> : 2.00 × 10 <sup>4</sup> (0.500 × 10 <sup>4</sup> )	0.050 × 10 <sup>5</sup> : 2.00 × 10 <sup>5</sup> (0.500 × 10 <sup>5</sup> )	0.050 × 10 <sup>6</sup> : 2.00 × 10 <sup>6</sup> (0.500 × 10 <sup>6</sup> )	0.050 × 10 <sup>7</sup> : 2.00 × 10 <sup>7</sup> (0.500 × 10 <sup>7</sup> )	0.050 × 10 <sup>8</sup> : 2.00 × 10 <sup>8</sup> (0.500 × 10 <sup>8</sup> )
25V	0.125 × 10 <sup>0</sup> : 5.00 × 10 <sup>0</sup> (1.25 × 10 <sup>0</sup> )	0.125 × 10 <sup>1</sup> : 5.00 × 10 <sup>1</sup> (1.25 × 10 <sup>1</sup> )	0.125 × 10 <sup>2</sup> : 5.00 × 10 <sup>2</sup> (1.25 × 10 <sup>2</sup> )	0.125 × 10 <sup>3</sup> : 5.00 × 10 <sup>3</sup> (1.25 × 10 <sup>3</sup> )	0.125 × 10 <sup>4</sup> : 5.00 × 10 <sup>4</sup> (1.25 × 10 <sup>4</sup> )	0.125 × 10 <sup>5</sup> : 5.00 × 10 <sup>5</sup> (1.25 × 10 <sup>5</sup> )	0.125 × 10 <sup>6</sup> : 5.00 × 10 <sup>6</sup> (1.25 × 10 <sup>6</sup> )	0.125 × 10 <sup>7</sup> : 5.00 × 10 <sup>7</sup> (1.25 × 10 <sup>7</sup> )	0.125 × 10 <sup>8</sup> : 5.00 × 10 <sup>8</sup> (1.25 × 10 <sup>8</sup> )
50V	0.250 × 10 <sup>0</sup> : 1.00 × 10 <sup>0</sup> (2.50 × 10 <sup>0</sup> )	0.250 × 10 <sup>1</sup> : 1.00 × 10 <sup>1</sup> (2.50 × 10 <sup>1</sup> )	0.250 × 10 <sup>2</sup> : 1.00 × 10 <sup>2</sup> (2.50 × 10 <sup>2</sup> )	0.250 × 10 <sup>3</sup> : 1.00 × 10 <sup>3</sup> (2.50 × 10 <sup>3</sup> )	0.250 × 10 <sup>4</sup> : 1.00 × 10 <sup>4</sup> (2.50 × 10 <sup>4</sup> )	0.250 × 10 <sup>5</sup> : 1.00 × 10 <sup>5</sup> (2.50 × 10 <sup>5</sup> )	0.250 × 10 <sup>6</sup> : 1.00 × 10 <sup>6</sup> (2.50 × 10 <sup>6</sup> )	0.250 × 10 <sup>7</sup> : 1.00 × 10 <sup>7</sup> (2.50 × 10 <sup>7</sup> )	0.250 × 10 <sup>8</sup> : 1.00 × 10 <sup>8</sup> (2.50 × 10 <sup>8</sup> )
100V	0.500 × 10 <sup>0</sup> : 2.00 × 10 <sup>0</sup> (5.00 × 10 <sup>0</sup> )	0.500 × 10 <sup>1</sup> : 2.00 × 10 <sup>1</sup> (5.00 × 10 <sup>1</sup> )	0.500 × 10 <sup>2</sup> : 2.00 × 10 <sup>2</sup> (5.00 × 10 <sup>2</sup> )	0.500 × 10 <sup>3</sup> : 2.00 × 10 <sup>3</sup> (5.00 × 10 <sup>3</sup> )	0.500 × 10 <sup>4</sup> : 2.00 × 10 <sup>4</sup> (5.00 × 10 <sup>4</sup> )	0.500 × 10 <sup>5</sup> : 2.00 × 10 <sup>5</sup> (5.00 × 10 <sup>5</sup> )	0.500 × 10 <sup>6</sup> : 2.00 × 10 <sup>6</sup> (5.00 × 10 <sup>6</sup> )	0.500 × 10 <sup>7</sup> : 2.00 × 10 <sup>7</sup> (5.00 × 10 <sup>7</sup> )	0.500 × 10 <sup>8</sup> : 2.00 × 10 <sup>8</sup> (5.00 × 10 <sup>8</sup> )
250V	1.25 × 10 <sup>0</sup> : 5.00 × 10 <sup>0</sup> (1.25 × 10 <sup>0</sup> )	1.25 × 10 <sup>1</sup> : 5.00 × 10 <sup>1</sup> (1.25 × 10 <sup>1</sup> )	1.25 × 10 <sup>2</sup> : 5.00 × 10 <sup>2</sup> (1.25 × 10 <sup>2</sup> )	1.25 × 10 <sup>3</sup> : 5.00 × 10 <sup>3</sup> (1.25 × 10 <sup>3</sup> )	1.25 × 10 <sup>4</sup> : 5.00 × 10 <sup>4</sup> (1.25 × 10 <sup>4</sup> )	1.25 × 10 <sup>5</sup> : 5.00 × 10 <sup>5</sup> (1.25 × 10 <sup>5</sup> )	1.25 × 10 <sup>6</sup> : 5.00 × 10 <sup>6</sup> (1.25 × 10 <sup>6</sup> )	1.25 × 10 <sup>7</sup> : 5.00 × 10 <sup>7</sup> (1.25 × 10 <sup>7</sup> )	1.25 × 10 <sup>8</sup> : 5.00 × 10 <sup>8</sup> (1.25 × 10 <sup>8</sup> )
500V	2.50 × 10 <sup>0</sup> : 1.00 × 10 <sup>0</sup> (2.50 × 10 <sup>0</sup> )	2.50 × 10 <sup>1</sup> : 1.00 × 10 <sup>1</sup> (2.50 × 10 <sup>1</sup> )	2.50 × 10 <sup>2</sup> : 1.00 × 10 <sup>2</sup> (2.50 × 10 <sup>2</sup> )	2.50 × 10 <sup>3</sup> : 1.00 × 10 <sup>3</sup> (2.50 × 10 <sup>3</sup> )	2.50 × 10 <sup>4</sup> : 1.00 × 10 <sup>4</sup> (2.50 × 10 <sup>4</sup> )	2.50 × 10 <sup>5</sup> : 1.00 × 10 <sup>5</sup> (2.50 × 10 <sup>5</sup> )	2.50 × 10 <sup>6</sup> : 1.00 × 10 <sup>6</sup> (2.50 × 10 <sup>6</sup> )	2.50 × 10 <sup>7</sup> : 1.00 × 10 <sup>7</sup> (2.50 × 10 <sup>7</sup> )	2.50 × 10 <sup>8</sup> : 1.00 × 10 <sup>8</sup> (2.50 × 10 <sup>8</sup> )
1000V	5.00 × 10 <sup>0</sup> : 2.00 × 10 <sup>0</sup> (5.00 × 10 <sup>0</sup> )	5.00 × 10 <sup>1</sup> : 2.00 × 10 <sup>1</sup> (5.00 × 10 <sup>1</sup> )	5.00 × 10 <sup>2</sup> : 2.00 × 10 <sup>2</sup> (5.00 × 10 <sup>2</sup> )	5.00 × 10 <sup>3</sup> : 2.00 × 10 <sup>3</sup> (5.00 × 10 <sup>3</sup> )	5.00 × 10 <sup>4</sup> : 2.00 × 10 <sup>4</sup> (5.00 × 10 <sup>4</sup> )	5.00 × 10 <sup>5</sup> : 2.00 × 10 <sup>5</sup> (5.00 × 10 <sup>5</sup> )	5.00 × 10 <sup>6</sup> : 2.00 × 10 <sup>6</sup> (5.00 × 10 <sup>6</sup> )	5.00 × 10 <sup>7</sup> : 2.00 × 10 <sup>7</sup> (5.00 × 10 <sup>7</sup> )	5.00 × 10 <sup>8</sup> : 2.00 × 10 <sup>8</sup> (5.00 × 10 <sup>8</sup> )

\*All resistance values are expressed in MΩ.

### 3. OPEARATING PRINCIPLE

The SM-8200 Series super megohmmeters consist of a constant voltage power supply and a high sensitive current measuring section to be combined to compose a resistance measuring circuit. The current measuring section is composed of a current detective resistor, low drift voltage amplifier and an integrator-type A/D converter. A measured resistance value is computation-processed by a CPU to display the result on a liquid crystal display (LCD).

Fig. 3.1 shows a circuit composition of the SM-8200 Series.

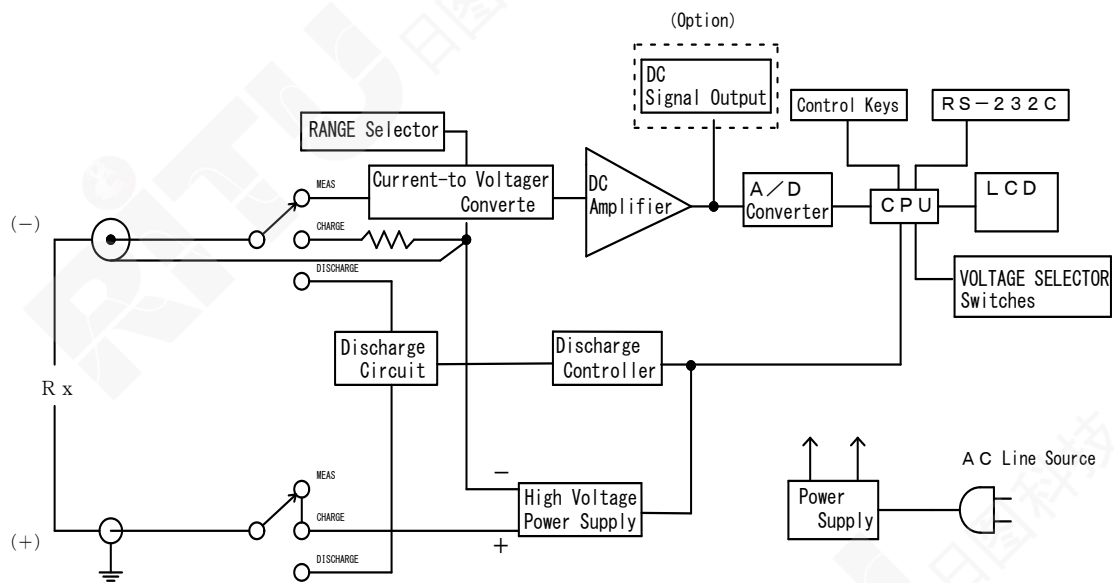

Fig. 3.1 Circuit Composition



## 4. FAMILIARIZATION WITH CONTROLS AND PARTS

### 4.1 Front Panel

The figure below shows the front panel of the SM-8200 Series. However, note that the values for the two knobs on the right are represented by those of the SM-8213.

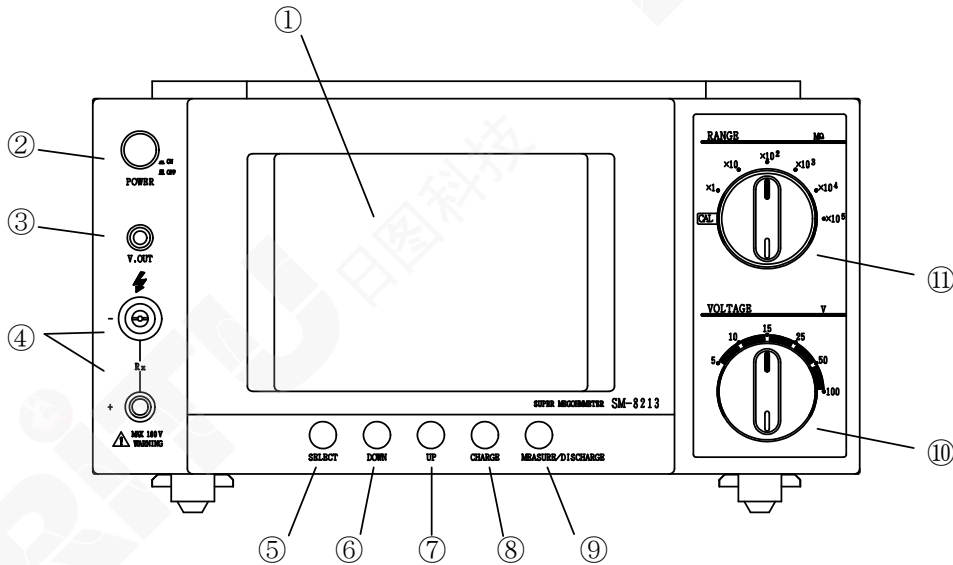

Fig. 4.1 Front Panel

- ① LCD Display: This is a  $320 \times 240$  dot liquid crystal display module.  
This shows measured results, measuring conditions and a variety of data settings.
- ② POWER Switch: This is a power switch to turn on or off the instruments.  
A press of this switch in the released position turns ON the unit.  
A press of this switch in the pushed position turns OFF the unit.
- ③ V. OUT Indicator: This indicator lights when the Rx -/+ measuring terminals carry a measuring voltage across them.
- ④ Rx -/+ Measuring Terminals: These terminals carry a selected measuring voltage across them to measure the insulation resistance of a sample via a pair of measuring rods or electrodes.

Note: Each of the terminals is incorporated with a plug insertion detector switch. Unless otherwise this switch is turned on by a full insertion of the plug of the measuring rod or electrode, the output voltage circuit cannot be completed – no output.  
Please be careful when inserting or removing the plug so as not to cause any impact on the detection switch inside the terminal.

- ⑤ SELECT Switch: This switch moves the cursor in the LCD display to the desired item set it.
- This switch also acts as a STOP switch; this switch makes the voltage on the Rx -/+ measuring terminals OFF when it is pressed while the measuring voltage is being applied.
- ⑥ DOWN Switch: This switch decreases the value to set each time it is pressed.
- ⑦ UP Switch: This switch increases the value to set each time it is pressed.
- ⑧ CHARGE Switch: This switch applies the measuring voltage across the Rx measuring terminals to charge the sample to be measured when it is pressed. During the charging period, the V. OUT indicator lights. the next press of this switch discharges the sample, turning off the V. OUT indicator.
- Note: When the timer function is used to determine the charging period, the measurement automatically starts when the set time is up.
- ⑨ MEASURE/DISCHARGE Switch: This switch starts a measurement of the sample in connection, when it is pressed, turning on the incorporated indicator and the V. OUT indicator.
- The next press of this switch discharges the sample, turning off the two indicators.
- ⑩ VOLTAGE Selector Switch: This switch selects the voltage to be applied across the Rx +/- measuring terminals. The arrow on the knob shows a voltage to output.
- ⑪ RANGE Selector Switch: This switch selects a factor for the measured value.
- The selected factor is also shown at the  $\boxed{\times 10}$  multiplier area.

## 4.2 Rear Panel

The figure below shows the rear panel of the SM-8200 Series. However, note that the VOLTAGE SELECTOR switches are set for the operation from 100 V AC line.

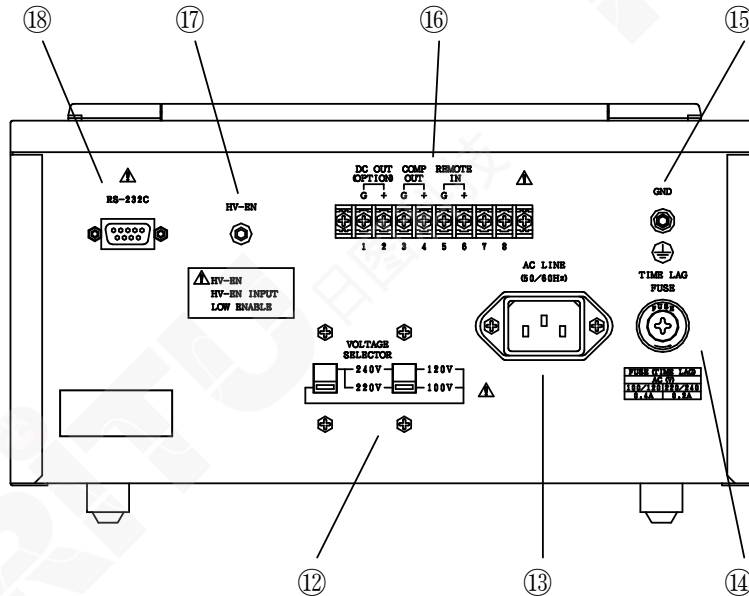

Fig. 4.2 Rear Panel

- ⑫ VOLTAGE SELECTOR Switches: These two switches are to be set in accordance with the local AC line voltage (50 or 60 Hz) for the instrument.
- For a proper setting, see 1.3 Setting VOLTAGE SELECTOR Switches. For line voltage change between 100 V/120 V and 220 V/240 V, the power fuse amperage must be also changed accordingly.

- ⑬ AC LINE Receptacle: This connects the accessory power cord.
- ⑭ TIME LAG FUSE Holder: This holder contains a time lag fuse in a glass tube. The amperage of the fuse must agree with the local AC line voltage from which the unit is powered.

<u>AC Line Voltage</u>	<u>Fuse Amperage</u>
100 V/120 V (50/60 Hz)	0.4 A
220 V/240 V (50/60 Hz)	0.2 A

Note: When the AC line voltage for the unit is changed after receipt of your super megohmmeter, check the fuse amperage.

- ⑮ GND Terminal: This is a ground terminal connected to the chassis of the unit.

- ⑩ External Input/Output Terminal Block: This terminal block carries signals measured result judgment outputs, optional DC output, and remote signal input.
- For details, see the following sections;
- 6.5 Comparison and Judgment Function
  - 8. MEMORY CONTROLLED MEASUREMENT
  - 9.2 DC Signal Output
- ⑪ HV-EN (High Voltage Enable) Interlocking Connector: This connector is provided for connection of an external interlocking switch on the measuring jig designed to block the application of a high voltage across the Rx +/- measuring terminals ④ for safety of the operator when the switch is in the off position.
- If such a switch is not provided, keep this connector plugged with the accessory shorting plug, instead.
- ⑫ RS-232C Interface Connector: This connector is provided for RS-232C interfacing. For details, see 7. RS-232C INTERFACE CONNECTIONS.

### 4.3 Measuring Display

In the measuring mode, the LCD display shows the resultant measured resistance value and its NO/GO judgment, as well as the measuring voltage and time.

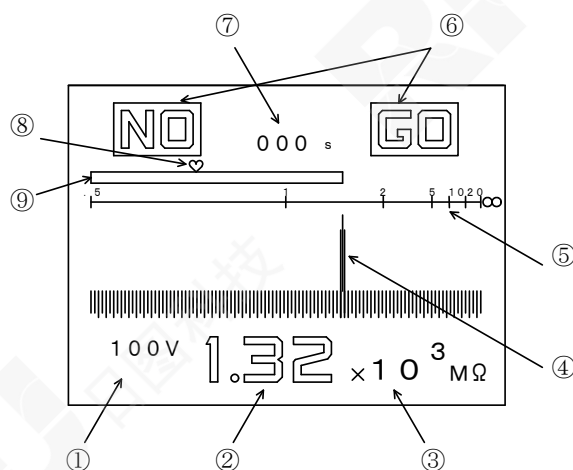

Fig. 4.3

- ① Test Voltage Indication: This shows the test voltage set with the VOLTAGE selector switch.
- ② Measured Resistance Indication: This shows the measured resistance in real time. When the measuring time is up, the final value is held until the next measurement will start.
- ③ Measuring Range Indication: This shows the measuring range set with the RANGE selector switch.
- ④ Analog Indicator: This shows the measured resistance value in analog referred to the analog resistance scale.
- ⑤ Analog Resistance Scale: This shows the scale for the analog indicator reading. When the measuring voltage is changed, the scale and values are changed, accordingly.
- ⑥ NO/GO Comparison Judgment Indication: When the NO/GO comparison judgment function is set on, a judgment of resultant resistance can be done referred to preset high/low limits. When the comparison judgment value is set to 000, the function becomes off.
- ⑦ Timer Count Indication: This is a count-down timer shown in seconds. When the timer is set to 000 sec., the function becomes invalid.
- ⑧ Comparison Judgment Value Mark: When the comparison judgment function is set on, a heart mark appears at a position showing the set value on the measured resistance bar graph.
- ⑨ Measured Resistance Bar Graph: This shows the measured resistance as a length of the bar.

#### 4.4 Measuring Condition Setting Display

The LCD display showing the measuring condition setting.

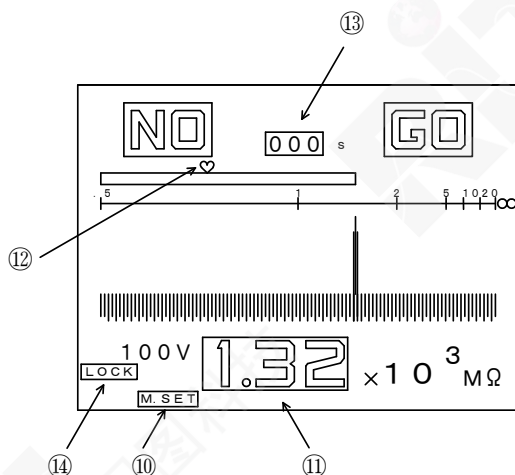

Fig. 4.4

- ⑩ **Status and Mode Notice:** When the MEASURE/DISCHARGE selector switch is set to the DISCHARGE position, press the SELECT switch to enter the setting mode, and the selected mode is shown in this box. Each time the SELECT switch is pressed, the mode is changed in the order; **C. SET** (voltage charging time setting mode) → **M. SET** (measuring time setting mode) → **COMP** (measured value comparison level setting mode) → **BUZZ** (buzzer sound level setting mode) →  (blank – measuring display).  
When the RANGE selector is set to the **CAL** position, **CAL1** is shown. With the **CAL1** status shown, the press of the SELECT switch changes the status to **CAL2**.
- ⑪ **Highlighted Comparison and Judgment Value:** When the COMP (comparison and judging level setting mode) is selected, the value is shown highlighted, and it can be changed with the UP and DOWN switches.
- ⑫ **Comparison and Judgment Value Mark:** This heart mark is shown when the comparison and judgment function is set to on, showing the position of the comparison and judgment level.
- ⑬ **Highlighted Judgment value:** This shows the judgment level which can be changed with the UP/DOWN switches.
- ⑭ **LOCK (Interlocking) Notice:** This shows that preparation for the measurement is not ready, yet. This notice is shown when the interlocking function is used to show that the HV-EN connector is free, and/or the Rx -/+ measuring terminals are free.  
When the LOCK notice is shown, the MEASURE and CHARGE switches become inoperative.

#### 4.5 Meanings of the Status and Mode Notices

This describes the meanings of the status and mode notice in the lower left corner of the LCD display.

- 1) **LOCK** (Interlocking): The test voltage applying circuit is interlocked, an measurement is not ready, yet. This notice is shown when the interlocking function is in use, but the HV-EN plug or measuring rod plug is not plugged into the connector.  
When the LOCK is shown, the MEASURE and CHARGE switches become inoperative.
- 2) **CAL1** (Calibration-1): This is shown when the RANGE selector switch is set to the **CAL** position.
- 3) **CAL2** (Calibration-2): This is shown when the SELECT switch is pushed while the **CAL1** notice is shown.
- 4) **C. SET** (Measuring voltage charging time setting mode): The time can be adjusted within a range from 0 to 999 seconds.
- 5) **M. SET** (Measuring time setting mode): The time can be adjusted within a range from 0 to 999 seconds.
- 6) **COMP** (Comparison judgment value setting mode): The value can be set within a range from the minimum value for the range to 10 times the value.
- 7) **BUZZ** (Buzzer ON/OFF setting mode): The buzzer can be set ON or OFF when the resultant comparison judgment is NO.

## 5. PREPARATION FOR A MEASUREMENT



### WARNING

Make sure, before turning the instrument on, that the VOLTAGE SELECTOR switches on the rear of the unit are properly set to the positions in agreement with the local AC line voltage. If the agreement is failed, the unit may break a fire or burning.



### WARNING

Be sure to connect the ground prong of the power cord plug to prevent danger. If grounding of the ground prong is impossible, connect GND terminal to the ground post of the power line system.

Note: For safety, the measuring voltage cannot be output unless otherwise the accessory shorting plug is plugged into the HV-EN connector on the rear of the unit. During measurement, the shorting plug must be kept plugged in.



### WARNING

Before trying to plug the shorting plug into the HV-EN connector, be sure to turn the POWER switch OFF.

### 5.1 Preparation

Confirm the setting of the instrument in the order shown below.

- 1) Confirm that the VOLTAGE SELECTOR switches on the rear of the unit are set to the positions in accordance with the local AC line voltage from which the unit is powered (See 1.3 Setting the VOLTAGE SELECTOR Switches.).
- 2) Confirm that the POWER switch of the unit is positioned at the OFF (released) position. Note that if the switch is in the ON position, it is depressed.
- 3) Plug the accessory power cord into the AC LINE receptacle on the rear of the unit. Also, plug the plug on the other end of the cord into the commercial AC line socket.



- 4) Confirm that the accessory shorting plug is inserted into HV-EN connector on the rear the unit.
- 5) Leave the Rx -/+ measuring terminals free at this stage – do not connect the measuring rods and the sample to be measured to the terminals.
- 6) Set the RANGE selector switch to the  $\times 1$  position – the minimum Multiplier.
- 7) Set the VOLTAGE SELECTOR switches to the lowest voltage available.
- 8) Turn the POWER switch ON.

Allow the unit to warm for a minimum of 30 seconds to obtain the specified performance. However, a measurement can be done after a warm-up of several seconds.

### 5.2 Self-calibration 1

- 1) Set the RANGE switch to the  $CAL$  position. (The display will show  $CAL1$ .) The calibration will be verified by the internal calibration circuit. Verify that the measured data display indicates a value within the range of  $.970$  to  $1.03$ .
- 2) If the value falls within the normal range, the self-calibration is complete. Set the RANGE switch to a position other than  $CAL$ . (If self-calibration 1 yields a result within the normal range, there is no need to perform self-calibration 2.)

### 5.3 Self-calibration 2

- 1) Press the **SELECT** switch while  $CAL1$  is being displayed. (The display will show  $CAL2$ ; see “4-4 Measurement Condition Setting Display” for more information.)
- 2) Increase the RANGE switch to the  $\times 10^2$  range.
- 3) Verify that the screen is displaying values with 5 digits and press the **SELECT** switch.
- 4) This completes self-calibration 2. **Repeat self-calibration 1 and verify that the value falls within the proper range.**

#### 5.4 Check the Measuring Rods

- 1) Confirm that V.OUT indicator turns off and that the Rx -/+ measuring terminals don't carry a measuring voltage across them.
- 2) Plug the accessory measuring rods to the Rx +/- measuring terminals until they are stopped. (Red measuring rod to the Rx - measuring terminal / Black measuring rod to the Rx + measuring terminal)
- 3) Set the RANGE selector switch to the  $\times 1$  position – the minimum Multiplier.
- 4) Set the VOLTAGE SELECTOR switches to the lowest voltage available.
- 5) Connect the measuring rods each other. Do not place the measuring rods anywhere.
- 6) Push MEASURE / DISCHARGE Switch.
- 7) Confirm that the analog indicating needle is shown leftward and that the indicated value is shown blinking.
- 8) Push MEASURE / DISCHARGE Switch. Confirm that the Rx -/+ measuring terminals don't carry a measuring voltage across them.
- 9) Separate the measuring rods.

## 5.5 Basic Procedures for a Measurement

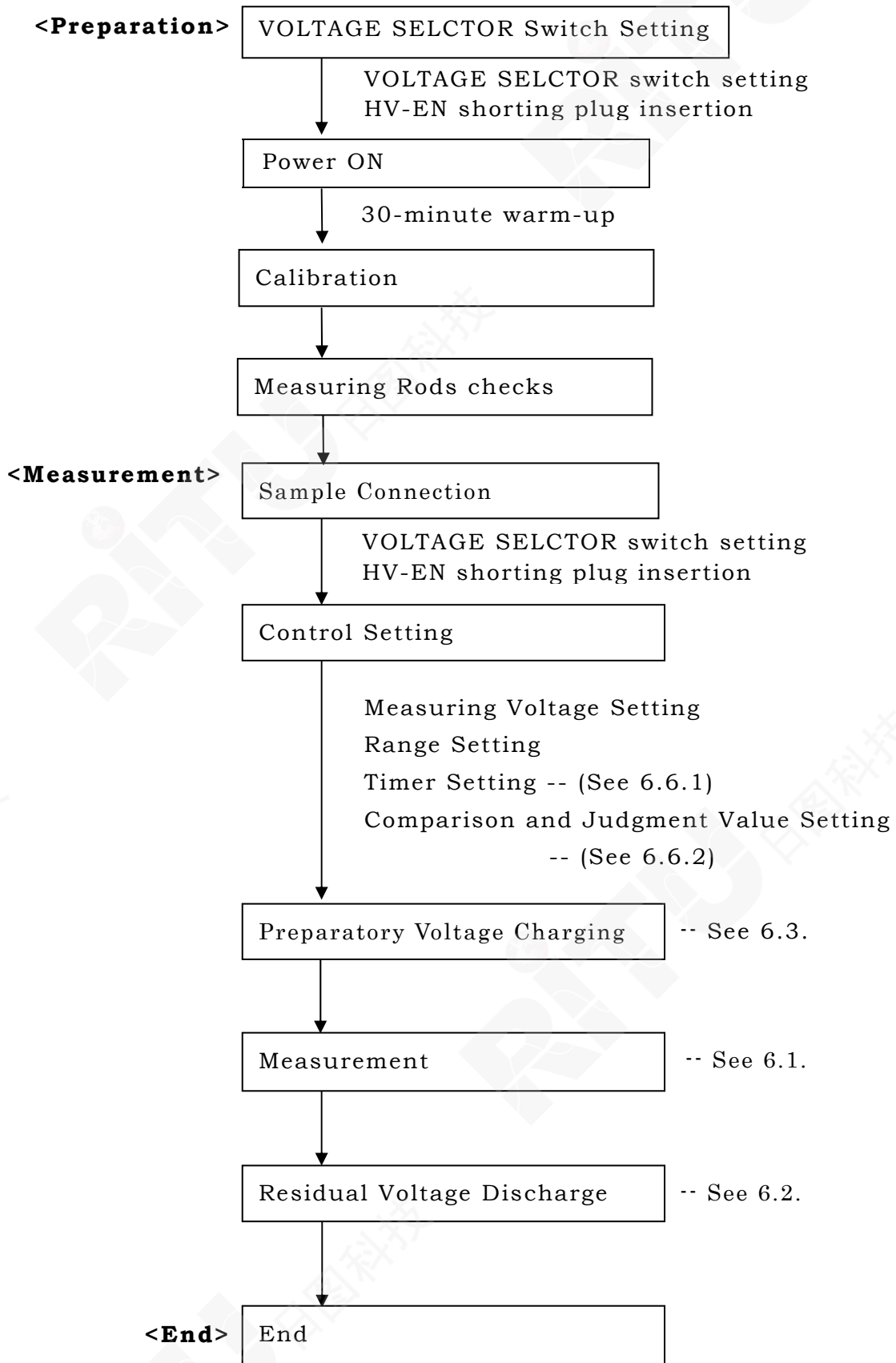

## 6. MEASUREMENT

### 6.1 Measuring Method

1) Plug the accessory measuring rods to the Rx +/- measuring terminals until they are stopped.

■ Red measuring rod to the Rx - measuring terminal

■ Black measuring rod to the Rx + measuring terminal

Note that each terminal has an incomplete plugging detection switch.

If the rod is incompletely plugged, the switch is left open, and the measuring voltage cannot be output.

2) Connect the measuring rods to the sample to measure.

Note 1: When one end of the sample is grounded, connect the black measuring rod to the grounded end. (See Fig. 6.1.1.)

Note 2: When one end of the sample has a larger surface area which is exposed to atmosphere than the other end, connect the black measuring rod to such an end. (See Fig. 6.1.2.)

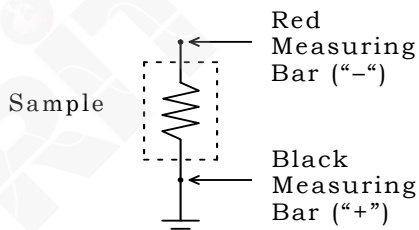

Fig. 6.1.1

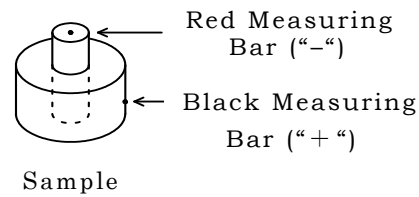

Fig. 6.1.2

3) Set the VOLTAGE selector switch to the voltage to be used for the measurement.

4) Set the RANGE selector switch to the range to be expected. If there is no idea about the approximate insulation value of the sample, set the selector to the  $\times 1$  range. Press the MEASURE switch to start a measurement. Change the position of the RANGE selector switch to find the most appropriate position to read the measured value. If the selector is set to a position out of the measured value, the indicated value is shown blinking.

Note 1: When the analog indicating needle is shown leftward, select a smaller range, while if the needle is shown rightward, select a larger range.

Note 2: To measure a capacitive sample within a possible shortest time, press the CHARGE switch to charge the sample as much as possible. Then, press the MEASURE switch to start a measurement. During the measurement, the measured value will be changed with time. In such a state, the elapsed time after voltage charging

becomes a significant parameter for the measuring conditions. In most cases, the value of 1 minute after voltage charging is read as a 1 minute rate value. The integrated timer can determine the value at 1 minute after voltage charging. For details, see 6.6.

Note 3: When a measuring jig is used, it is recommended to provide an interlocking switch with it for safety. For the interlocking, utilize the HV-EN (high voltage enable) socket on the rear of the unit. This makes it possible to disarm the jig when the cover of the jig is opened. For details, see 6.4.

## 6.2 Discharge Function

This function is intended to discharge the charge on the sample connected to the Rx -/+ measuring terminals. Discharging is automatically performed each time the super megohmmeter is turned on, and the measurement is ended. The sample after measurement must be disconnected from the terminals after the discharging function is performed.

Status of the MEASURE/DISCHARGE switch can be known by the indicator.

Indicator ON ----- MEASURE  
OFF ----- DISCHARGE

In the DISCHARGE status, a resistor of approx. 100 k $\Omega$  is internally inserted to discharge the charge of the sample.

A time required to discharge the charge of the sample depends on the capacitance of the sample. When the capacitance of the sample is 1  $\mu$  F, it takes approx. 1 seconds to reduce the residual voltage down to 5% of the charged value.

Note: The discharge function does not work if the POWER switch is kept OFF.

## 6.3 Charge Function

To measure a capacitive sample, charge it with the measuring voltage by pressing the CHARGE switch. Then, the charge of the sample is completed within several seconds.

There is no rule to determine the charging time, it is necessary to set it to a fixed time to make the measuring conditions unchanged among samples.



### WARNING

When the super megohmmeter is in the charge status do not touch the Rx -/+ measuring terminals and the sample being charged. The measuring voltage selected with the VOLTAGE switch is directly applied to these parts because there is a fear of electrical shock.

## 6.4 Interlocking Function – Using the HV-EN Connector

The super megohmmeter generates a high voltage to be used as a testing power source. It is dangerous if this measuring voltage is output to the sample not ready for measurement, yet. To protect the operator from a hazard of electrical shock, the HV-EN (high voltage enable) connector is provided on the rear of the unit to provide an interlocking function in combination with a measuring jig.

If a measurement does not use a jig with an interlocking mechanism, keep the HV-EN connector plugged with the accessory shorting plug.

### Usage of the HV-EN Connector for Interlocking

Connect the HV-EN connector to a switch to be actuated by the interlocking mechanism of a measuring jig via an optionally available HV-EN plug connected with a cord. Fig. 6.4.1 shows an example interlocking circuit.

The optional accessories shown below have a safety interlocking switch.

SME-8310 – Electrode for plate samples

SME-8311 – Electrode for plate samples

SME-8350 – Shield box

Connect the plug at the end of the measuring cord of the optional accessory to the HV-EN connector on the rear of the unit.

For connection of a customer designed measuring jig to the HV-EN connector, use an optional HV-EN plug.

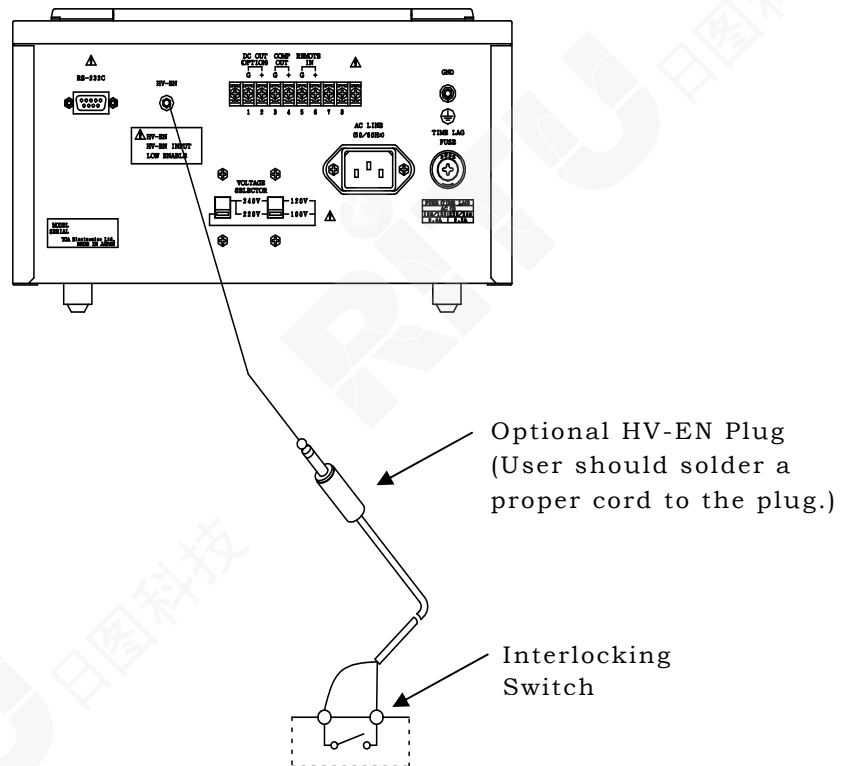

Fig. 6.4.1

## 6.5 Comparison and Judgment Function

This function is provided to sound a built-in buzzer, and turn on the COMP OUT G/+ terminals when the measured insulation resistance is lower than the preset judgment value and make the COMP OUT G/+ terminals are of open collector as shown as an equivalent circuit in Fig. 6.5.3. Use this circuit within the conditions shown below:

Voltage: 50 V or less

Current: 50 mA or less

Fig. 6.5.1 shows a circuit diagram for connection with the COMP OUT terminals.

Fig. 6.5.2 shows the external input/output terminal block, including the COMP OUT G/+ terminals.

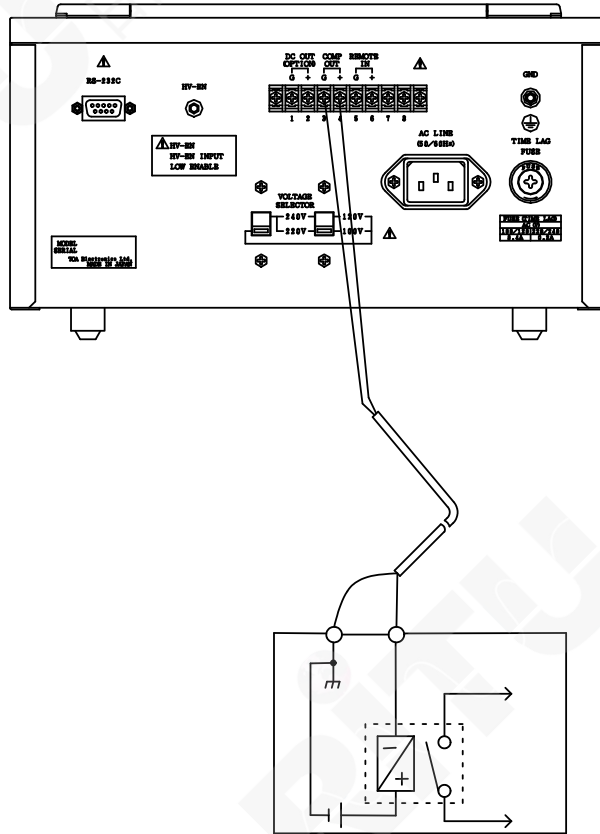

Fig. 6.5.1

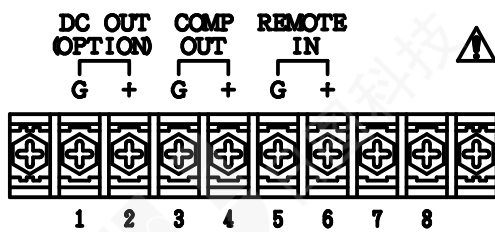

Fig. 6.5.2

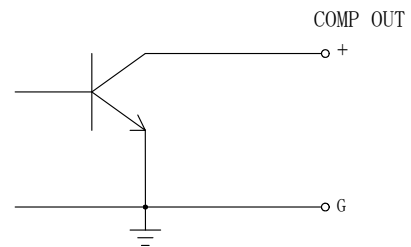

Fig. 6.5.3

## 6.6 Setting a Variety of Functions

A variety of useful functions can be set when the RANGE selector switch is set to any position other than the **CAL**, and by using the **SELECT**, **UP** and **DOWN** switches.

Each time the **SELECT** switch is pushed, the LCD display is changed in the order of the **Measuring Display** → **C. SET** → **M. SET** → **COMP.** → **BUZZ** → **Measuring Display**.

**C. SET** : Charging timer setting

**M. SET** : Measuring time setting

**COMP.** : GO/NO judgment level setting

**BUZZ** : Buzzer sound ON/OFF setting

### 6.6.1 Setting the Timer

Example: Setting a measuring time to 50 seconds

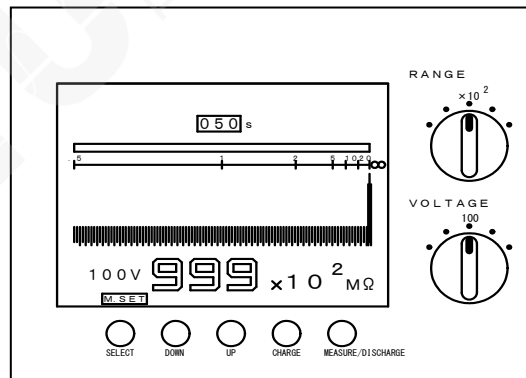

Fig. 6.6.1

- 1) Press the **SELECT** switch twice to show the **M. SET** indication in the lower left area of the LCD for the measuring timer setting mode.
- 2) Using the **UP** and **DOWN** switches, set the time indication in the upper center area of the display to **050** seconds.
- 3) Press the **SELECT** switch 3 times to return to the measuring display. To accelerate the change of a value, keep the corresponding **UP** or **DOWN** switch pushed.

### 6.6.2 Setting the Comparison GO/NO Judging Level

Example: Setting a judgment of  $NO < 100M\Omega \leq GO$  for 100 V test voltage

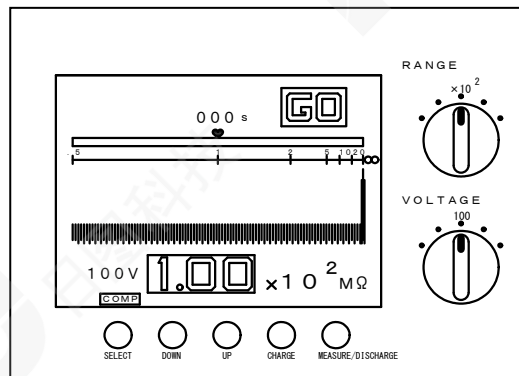

Fig. 6.6.2



- 1) Set the VOLTAGE selector switch to  $100\text{ V}$ .
  - 2) Set the RANGE selector switch to  $\times 10^2$ .
  - 3) Press the SELECT switch 3 times to show the COMP indication in the lower left area of the LCD for the comparison GO/NO judgment level.
  - 4) Using the UP and DOWN switches, set the GO/NO judgment level to  $1.00 \times 10^2\text{ M}\Omega$ .
  - 5) Press the SELECT switch twice to return to the measuring display.
- To accelerate the change of a value, keep the corresponding UP or DOWN switch pushed.

Note: The comparison GO/NO judgment level setting can be effective for the currently set RANGE and VOLTAGE values, only. If setting is required for other RANGE and VOLTAGE values, set desired RANGE and VOLTAGE, first.

### 6.6.3 Setting Buzzer Sound ON/OFF

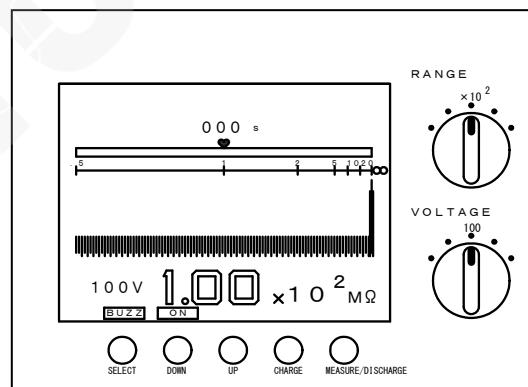

Fig. 6.6.3

- 1) Press the SELECT switch 4 times to show the BUZZ indication in the lower left area of the LCD for the buzzer sound ON/OFF setting.
- 2) Using the UP and DOWN switches, set ON or OFF.
- 3) Press the SELECT switch once to return to the measuring display.

### 6.6.4 Setting Charging Time, Measuring Time, Comparison GO/NO Judging Level and Buzzer Sound ON/OFF

Example: Setting for measuring conditions below:

Charging Time: 10 seconds

Measuring Time: 50 seconds

Comparison Level:  $\text{NO} < 100\text{ M}\Omega \leq \text{GO}$  judgment

Buzzer Sound: Buzzer sounds when NO judgment is resulted.

RANGE Position:  $\times 10^2$

VOLTAGE Position: 100 V

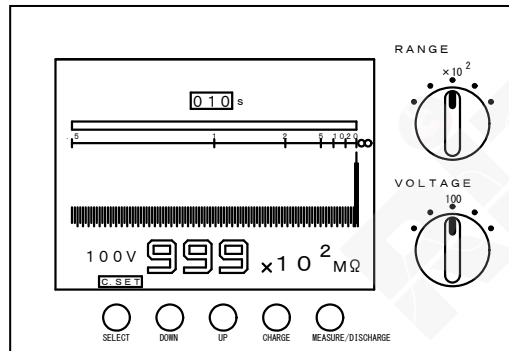

Fig. 6.6.4

- 1) Set the VOLTAGE selector switch to  $100\text{ V}$ .
- 2) Set the RANGE selector switch to  $\times 10^2$ .
- 3) Press the SELECT switch to show the C. SET indication for charging time setting mode.
- 4) Using the UP or DOWN switch, set the charging time to  $010$  seconds. (Fig. 6.6.4)
- 5) Press the SELECT switch to enter the value of  $010$ . This action provides the measuring time setting mode, showing the M. SET indication.
- 6) Using the UP and/or DOWN switches, set the measuring time to  $050$  seconds.
- 7) When this value is OK, press the SELECT switch to enter it. This action provides the judgment level setting mode, showing the COMP indication.
- 8) Using the UP and/or DOWN switches, set the judgment level to  $1.00 \times 10^2\text{ M}\Omega$ . (Fig. 6.6.2)
- 9) When this level is OK, press the SELECT switch to enter it. This action provides the buzzer sound on/off setting mode, showing the BUZZ indication.
- 10) Using the UP and/or DOWN switches, set ON or OFF for the buzzer. (Fig. 6.6.3)
- 11) Press the SELECT switch to end the measuring condition setting mode, and go back to the measurement screen.

After setting the measuring conditions as shown in the example, press the CHARGE switch. Then, the measurement starts after a charging period of 10 seconds.

Note 1: The set measuring conditions are stored in the memory, and the contents are kept backed up even if the power is turned off.

Note 2: The comparison judgment level settings are valid only for the range and test voltage used for setting. For other ranges and test voltages, change the settings, accordingly.

## 6.7 Changes in the Current Flowing through an Insulator

In insulation resistance measurements, a large amount of current flows upon the application of the test voltage to the insulator. The current gradually reduces its value with time, but it takes a time until the value becomes stable and fixed. This phenomena is due to the combination of the charging current, absorption current, and leakage current, and it is generally called dielectric absorption phenomena. The equivalent circuit of an insulator is considered as shown in Fig. 6.7.1.

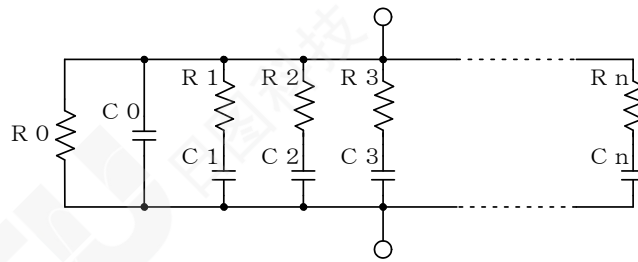

Fig. 6.7.1

When a voltage is applied to the circuit, a charging current flows through a bank of capacitors,  $C_0, C_1, C_2, \dots, C_n$ . Firstly,  $C_0$  is charged, and other capacitors follow. As the charging progresses the current through  $R_0$  constantly flows as shown in Fig. 6.7.2.

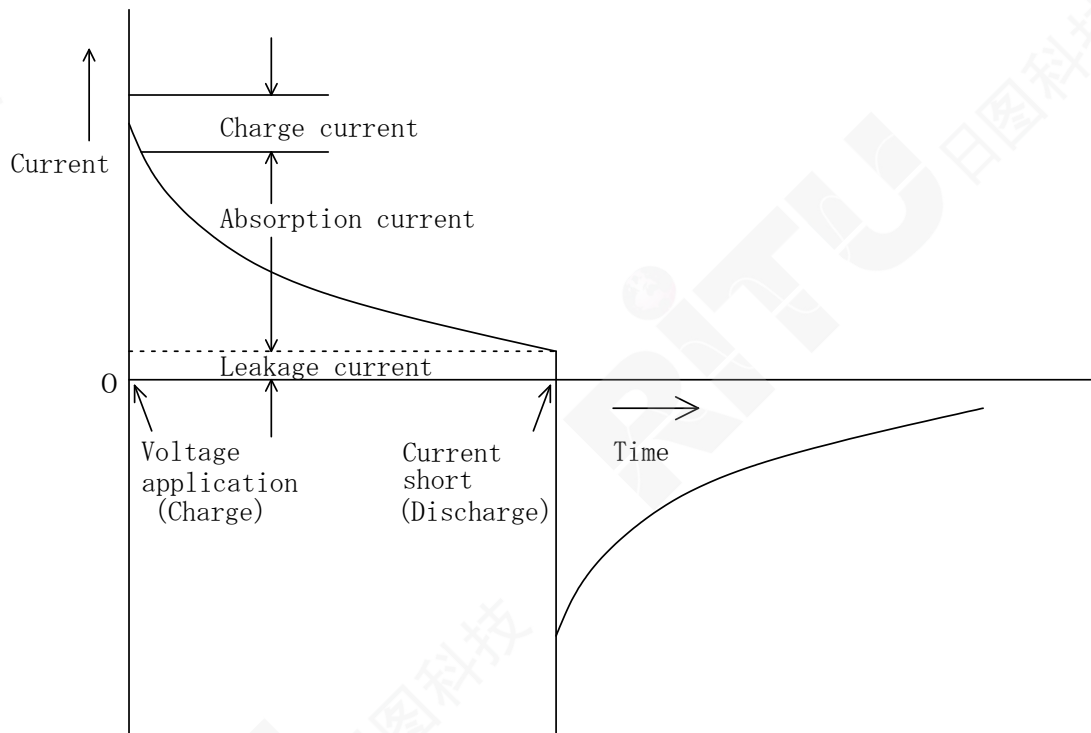

Fig. 6.7.2

$R_0$  is an insulation resistance to be measured, but,  $C_0, C_1, C_2, \dots, C_n$

Have series resistors  $R_0, R_1, R_2, \dots, R_n$ . Therefore, a measurement of  $R_0$  only is very difficult. It is said that, with some insulation resistance measurements, it takes several hours to a few days for the leakage current to stabilize. This is not practical.

To avoid this problem, a method is customarily used in the insulation resistance measurement for convenience to read the resistance value one minute after charging the test voltage to the sample. This value is called minute rate value for the resistance value of an insulator, and is widely employed among a variety of electrical standards.

In the 1-minute rate insulation resistance measurement, the measured values may vary when a measurement is repeated once or twice with the same sample. To minimize such a deviation, it is important to completely discharge the sample before the start of each measurement. The required discharge time mainly depends upon the charging voltage and the size of  $C_0$  in Fig. 6.7.1, but, generally it can be said to be 5 to 6 times longer than the time of test voltage charging.

## 6.8 Connectivity Precautions

### 6.8.1 When the Screen Shows **LOCK** and Measurement Cannot Be Started

The super megohmmeter can output measurement voltages of up to 1,000 V. Consequently, failure to wire the instrument correctly may pose hazards such as electric shock. The instrument provides an interlock function in order to prevent these risks. An HV-EN (high-voltage enable) connector is provided for interlock function use on the rear of the instrument.

When using the measuring rods (red/black) that come with the instrument, insert the shorting plug into the HV-EN connector on the rear of the instrument. If **LOCK** is displayed at the bottom left of the instrument's screen, check the following:

- (1) Has the measuring rod (black) been properly inserted into the Rx+ terminal?
- (2) Has the shorting plug been properly inserted into the HV-EN connector on the rear of the instrument?

Display of the **LOCK** indicator at the bottom left of the screen indicates that the instrument has detected an issue with the measuring rod or shorting plug wiring.

### **6.8.2 When Using an Optional Electrode for Plate Samples or Shield Box**

When using an electrode for plate samples (for example the SME-8310; or the SME-8350 shield box, etc.), which is an option designed specifically for use with the megohmmeter, the following guidelines should be observed when wiring the instrument and performing measurements:

- 1) To prevent the hazard of electric shock, be sure to ground either the ground pin of the 3-pin power cable or the ground terminal on the rear of the instrument before use. When using a power plug conversion adapter (3-pin to 2-pin conversion adapter), be sure to ground the ground lead from the adapter.
- 2) Connect the option's red cable to the instrument's Rx- terminal and the option's black cable to the instrument's Rx+ terminal.
- 3) Remove the shorting plug from the HV-EN connector on the rear of the instrument.
- 4) Connect the interlock (HV-EN) plug from the electrode for plate samples or the shield box to the HV-EN connector on the rear of the instrument.
- 5) When using the SME-8350 shield box, directly ground the shield box's ground terminal or connect it to the ground terminal on the megohmmeter.  
\*When using a shield box, failure to ground the ground terminal may cause measured values to oscillate.
- 6) Completely close the electrode for plate samples and shield box lid. (Starting measurement without first closing the lid completely will trigger the hazard prevention interlock.)

## 7. RS-232C INTERFACE

### 7.1 RS-232C Communication Commands

Mnemonic	Contents	Format
R	Measuring Data Output	Format: R <sup>C<sub>R</sub></sup> L <sub>F</sub> Response: ****E*, Judgment [GO] 0 or [NO] 1 Example: 10.0E4, 0 <sup>C<sub>R</sub></sup> L <sub>F</sub>
M	Starting a Measurement	Format: M <sup>C<sub>R</sub></sup> L <sub>F</sub> Response: 0 (valid) or 1 (invalid)
C	Starting a Charging	Format: C <sup>C<sub>R</sub></sup> L <sub>F</sub> Response: 0 (valid) or 1 (invalid)
S	Stopping Forcedly	Format: S <sup>C<sub>R</sub></sup> L <sub>F</sub> Response: 0 (valid) or 1 (invalid)
T	Measuring Time Setting	Format: T *** (000 to 999) <sup>C<sub>R</sub></sup> L <sub>F</sub> Example: T 60 <sup>C<sub>R</sub></sup> L <sub>F</sub> Response: 0 (valid) or 1 (in valid)
G	Charging Time Setting	Format: G *** (000 to 999) <sup>C<sub>R</sub></sup> L <sub>F</sub> Example: G 120 <sup>C<sub>R</sub></sup> L <sub>F</sub> Response: 0 (valid) or 1 (in valid)
P	Judgment Level Setting	Format: P *** (000 to 999) <sup>C<sub>R</sub></sup> L <sub>F</sub> Example: P . 100 <sup>C<sub>R</sub></sup> L <sub>F</sub> Response: 0 (valid) or 1 (in valid)
B	Judgment Buzzer Setting	Format: B [OFF] 0 or [ON] 1 <sup>C<sub>R</sub></sup> L <sub>F</sub> Example: B 1 Response: 0 (valid) or status
U	Measuring Condition Output	Format: U <sup>C<sub>R</sub></sup> L <sub>F</sub> Response: Range, Voltage, interlocking, Status Example: 4, 1000, 0, 2 <sup>C<sub>R</sub></sup> L <sub>F</sub> Range: 0 to 8 Voltage: 5 to 1000 Interlocking: 0[OFF]/1[ON] Status: Stand-by - 2 Under measurement - 3 Charging - 4 On setting - 5 Under calibration - 6 Timer in operation - 7
I	Instrument ID	Format: I <sup>C<sub>R</sub></sup> L <sub>F</sub> Response: Model, Version Example: SM-8215V1.00 <sup>C<sub>R</sub></sup> L <sub>F</sub>

Baud Rate	9600 bps
Data Bit	8 bit
Parity Bit	None
Stop Bit	1 bit
Flow Control	RTS/CTS possible

## 7.2 Applications of Commands

- 1) After each command transmission, make sure to receive the response.
- 2) For R command, a state only response will be received, depending upon the conditions at such a time.  
Even during measurement, a state 7 only response will be received when the timer is functioning.  
During stand-by, measured data are transmitted once. A command invalid will be transmitted except for after re-measurement.
- 3) If a charging time is set upon receipt of a C command, a measurement is started as soon as the charging is completed.
- 4) For a P command, if a value out of the specified measuring range is received without an actual setting.

## 7.3 Connector Specifications

Type of Connector: HDBE-9PF (05) [Hirose]

Type of Lock Fitting – HD-LNA (4-40), inch type

Pin Arrangement:

Pin No.	Signal Line	Direction of Signal Flow		Application
		Megohmmeter	External Unit	
1	NC			No connection
2	TD		→	Transmission data
3	RD	←		Receiving data
4	NC			No connection
5	SG			Signal ground
6	ER		→	Data peripheral ready
7	CS	←		Send ready signal
8	RS		→	Send request signal
9	NC			No connection

Example of Connections

- 1) For connection with a DOS/V personal computer, use a straight 9-pin to 9-pin cable.

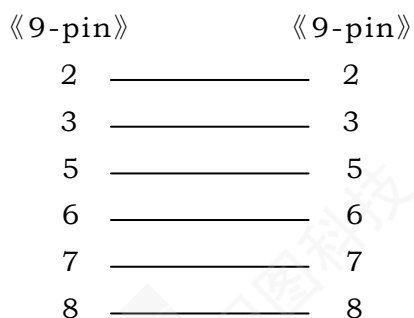

- 2) For connection with an NEC PC-9801 Series personal computer, use a straight 9-pin to 25-pin cable.

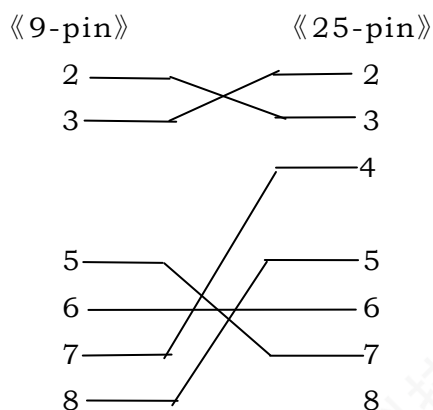

#### 7.4 Printer Output

Via the RS-232C interface, measured data can be output to an optional printer, 9442.

[Printer Output Procedures]

- 1) Connect the RS-232C interface connector on the rear of the unit, to the optional printer via the dedicated connection cord.
- 2) Set the measuring intervals as needed. (See Fig. 6.6.1.)
- 3) Press the **MEASURE** switch.
- 4) When the measurement is completed, the measured data are output to the printer.

Example:

Measured Data –  $10.0 \times 10^4 \text{ M}\Omega$ , GO judgment

Printing – 10.0E4, 0



## 8. REMOTELY CONTROLLED MEASUREMENT

A measurement can be remotely controlled by shorting the “G” and “+” terminals of the REMOTE IN of the External Input/Output terminal block on the rear of the unit. When the terminals are shorted by a remote switch, a measurement will start, and when opened the measurement is ended.

Fig. 8.1.1 shows an example wiring and the signal timing.  
 Fig. 8.1.2 shows the external input/output terminal block.

### ■ Signal Timing

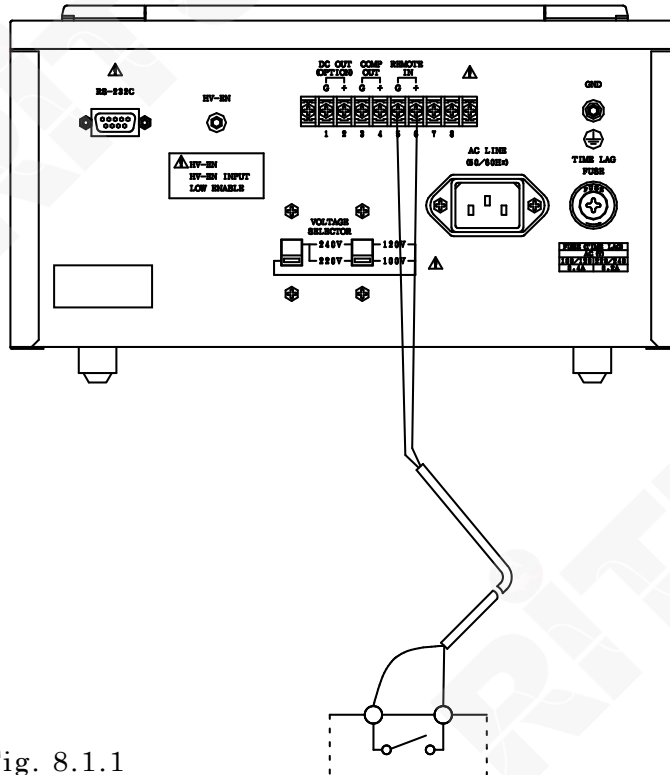
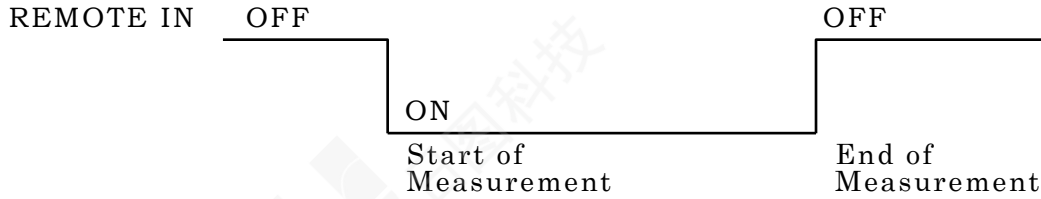

Fig. 8.1.1

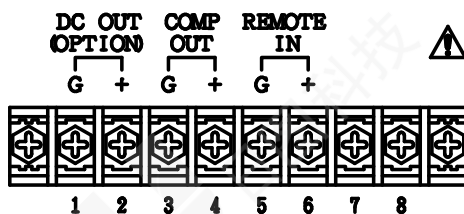

Fig. 8.1.2

## 8. Remotely controlled measurement — Supplement —

Indication of numeric and GO/NO judgement are conducted after converting analog input to digital signal.

Since it takes approx. 200mS to process analog/digital conversion, measuring result does not come out actually, if the remote signal is input in a shorter time than it.

In the process of detecting the remote signal, if the signal does not keep for approx. 60ms or more from the variation point of remote signal in order to cancel the noises and chattering, it is not treated as effective one.

As a result, it will take approx. 260ms from the remote signal ON to output of measuring result and during this time it is needed to keep remote signal ON.

When measurement is completed by turning remote signal off, it is not treated as normal OFF input signal if it is not kept approx. 60 ms or more.

When remote signal ON or OFF time is less than 60ms, it will be not received or lead to miss-operation.

When remote signal is used, care must be taken to input the signal for 260ms or more at ON, while 60ms or more at OFF.

Note 1: When the measuring time is set with the incorporated timer, the timer has a priority over a remotely controlled switch actuation.

When the REMOTE IN “G” and “+” terminals are closed, a measurement will start. The measurement will automatically end when the time set with the timer is up.

Note that when the closed “G” and “+” terminals are opened before the time-up of the timer, the opening of the “G” and “+” terminals has a priority over the time set with the timer.

Note 2: When the charging time is set with the incorporated timer, the timer has a priority over a remotely controlled switch actuation.

When the REMOTE IN “G” and “+” terminals are closed, a charging will start. The measurement will automatically start when the charging time set with the timer is up.

Note that when the closed “G” and “+” terminals are opened before the time-up of the timer, the opening of the “G” and “+” terminals has a priority over the time set with the timer.

Note 3: When both the charging time and measuring time are set with the incorporated timer, the timer has a priority over a remote control.

When the REMOTE IN “G” and “+” terminals are closed, a charging will start.

When the set charging time is up, a measurement automatically starts. However, note that when the “G” and “+” terminals are opened before the set measuring time is up, the remote control has a priority over the time set with the timer.

When the set measuring time is up, a measurement automatically ends. However, note that when the “G” and “+” terminals are opened before the set measuring time is up, the remote control has a priority over the time set with the timer.

## 9. INTRODUCTION OF OPTIONS

With the SM-8200 Series super megohmmeters, any of the following options can be provided as needed. However, note that some of them can be installed at factory.

### 9.1 DC Signal Outputs

Either one of two different types of DC signal outputs can be optionally installed with the unit at factory. The output can be used to make a permanent record of measured data by connecting a chart recorder.

One of the outputs provides a linear DC signal directly proportional to the measured resistance (RP-8000), and the other outputs a 1/R DC signal which is inversely proportional to the measured resistance (RI-8000).

#### 9.1.1 DC Output, RP-8000 – Directly proportional or linear to resistance

An insulation resistance can be obtained when the measuring voltage is divided by the current flowing through the circuit. When the measuring voltage is constant, if the insulation resistance is doubled, the current flowing through the circuit is halved. The RP-8000 DC output is designed to convert the measured insulation resistance into a DC signal directly proportional to the resistance.

##### 1) Specifications

Output Range: From minimum value of each range of super megohmmeter to 10 times minimum value(see 2.1)

Output Voltage: 1V/minimum value , 10 V/10 times minimum value

Output Accuracy: Within 10% of displayed value in the range from minimum value to 10 times minimum value

##### 2) Usage

Measure the insulation resistance of a sample with the method designed in 6.1 Measuring Method. There is no limitation in the applications in relation with the provision of the RP-8000 DC output.

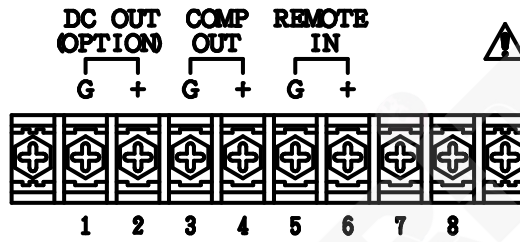

Fig. 9.1.1

Fig. 9.1.1 shows the DC OUT (OPTION) “G”/”+” terminals on the external input/output terminal block on the rear of the unit.

A DC measuring instrument like a HIOKI chart recorder can be connected to these terminals. For permanent data recording, a HIOKI chart recorder is recommended for better technical follow-up, including a supply of a variety of recording charts and technical service.

### 3) Output voltage

These tables show the relations between displayed value of super megohmmeter and output voltage of RP-8000.

#### Target voltage 5V

Displayed value	0.025	→	0.125	→	0.25
Output voltage	1V	→	5V	→	10V

#### Target voltage 10V

Displayed value	0.05	→	0.25	→	0.5
Output voltage	1V	→	5V	→	10V

#### Target voltage 15V

Displayed value	0.075	→	0.375	→	0.75
Output voltage	1V	→	5V	→	10V

#### Target voltage 25V

Displayed value	0.125	→	0.625	→	1.25
Output voltage	1V	→	5V	→	10V

#### Target voltage 50V

Displayed value	0.25	→	1.25	→	2.5
Output voltage	1V	→	5V	→	10V

#### Target voltage 100V

Displayed value	0.5	→	2.5	→	5
Output voltage	1V	→	5V	→	10V

Target voltage 250V

Displayed value	1.25	→	6.25	→	12.5
Output voltage	1V	→	5V	→	10V

Target voltage 500V

Displayed value	2.5	→	12.5	→	25
Output voltage	1V	→	5V	→	10V

Target voltage 1000V

Displayed value	5	→	25	→	50
Output voltage	1V	→	5V	→	10V

Example

- SM-8220

Target voltage : 500V

RANGE :  $\times 10^5$

Measurement range :  $2.5 \times 10^5 \text{ M}\Omega$  to  $100 \times 10^5 \text{ M}\Omega$

- Output voltage of RP-8000

Output range :  $2.5 \times 10^5 \text{ M}\Omega$  to  $25 \times 10^5 \text{ M}\Omega$

Output voltage :  $1\text{V}/2.5 \times 10^5 \text{ M}\Omega$  ,  $10\text{V}/25 \times 10^5 \text{ M}\Omega$

### 9.1.2 DC Output, RI-8000 – 1/R or inversely proportional to resistance

In insulation resistance, as described in 9.1.1 DC Output, RP-8000, if the measuring voltage is constant, the current flowing through the sample is halved, and the output voltage is also halved when the insulation resistance -- R -- is doubled. This relation can be expressed as "1/R." The RI-8000 provides this type of DC signal output.

#### 1) Specifications

Output Range: Full range of the measuring range of the SM-8200 Series super megohmmeter

Output Voltage:  $10\text{V}/\text{minimum value}$  ,  $1\text{V}/10 \text{ times minimum value}$

Output Accuracy: Within 10% of displayed value in the range from minimum value to 10 times minimum value

#### 2) Usage

Measure the insulation resistance of a sample with the method designed in 6.1 Measuring Method. There is no limitation in the applications in relation with the provision of the RI-8000 DC output. Fig. 9.1.1 on the previous page shows the DC OUT (OPTION) "G"/"+" terminals on the external input/output terminal block on the rear of the unit.

A DC measuring instrument like a HIOKI chart recorder whose input impedance is greater than 10 MΩ can be connected to these terminals. For permanent data recording, a HIOKI chart recorder is recommended for better technical follow-up, including a supply of a variety of recording charts and technical service.

### 3) output voltage

These tables show the relations between displayed value of super megohmmeter and output voltage of RI-8000.

#### Target voltage 5V

Displayed value	0.025	→	0.05	→	0.25
Output voltage	10V	→	5V	→	1V

#### Target voltage 10V

Displayed value	0.05	→	0.1	→	0.5
Output voltage	10V	→	5V	→	1V

#### Target voltage 15V

Displayed value	0.075	→	0.15	→	0.75
Output voltage	10V	→	5V	→	1V

#### Target voltage 25V

Displayed value	0.125	→	0.25	→	1.25
Output voltage	10V	→	5V	→	1V

#### Target voltage 50V

Displayed value	0.25	→	0.5	→	2.5
Output voltage	10V	→	5V	→	1V

#### Target voltage 100V

Displayed value	0.5	→	1	→	5
Output voltage	10V	→	5V	→	1V

#### Target voltage 250V

Displayed value	1.25	→	2.5	→	12.5
Output voltage	10V	→	5V	→	1V

#### Target voltage 500V

Displayed value	2.5	→	5	→	25
Output voltage	10V	→	5V	→	1V

Target voltage 1000V

Displayed value	5	→	10	→	50
Output voltage	10V	→	5V	→	1V

Example

- SM-8220

Target voltage : 100V

RANGE :  $\times 10^3$

Measurement range :  $0.5 \times 10^3 \text{ M}\Omega$  to  $20 \times 10^3 \text{ M}\Omega$

- Output voltage of RI-8000

Output range :  $0.5 \times 10^3 \text{ M}\Omega$  to  $5 \times 10^3 \text{ M}\Omega$

Output voltage :  $10\text{V}/0.5 \times 10^3 \text{ M}\Omega$  ,  $1\text{V}/5 \times 10^3 \text{ M}\Omega$



## **10. MAINTENANCE AND MISCELANEOUS**

Periodical maintenance, including checking and calibration is required for the MS-8200 super megohmmeter to perform reliable measurements and prevent a trouble and accident.

If necessary, ask your dealer or Hioki representative to do such a service as periodical checking, calibration and routine maintenance.

### **10.1 Periodical Checking**

To keep your instrument its at best condition, the following checking is required at monthly periods.

- 1) Check the Rx measuring terminals and input/output terminal block for integrity.

As the Rx measuring terminals carry a high voltage (100 V to 1000 V, maximum, depending upon the model and set-up, visually check the terminals for any crack, loose connection, etc.

Crack and loose connection will lead a trouble and accident.

- 2) Clean the panels, Rx measuring terminals, and input/output terminal board with soft cloth.
- 3) Visually check the LCD display for brightness and clearness.
- 4) Check the action of the switches and pushbutton switches for smooth and trouble-free operation.
- 5) Measure the measuring voltage across the Rx -/+ measuring terminals With a voltmeter. The voltage should be within  $\pm 3\%$  of the selected value.

### **10.2 Storage, Transportation and Abandon**

- 1) Storage

When the SM-8200 Series unit is shutdown for a long period of time, unplug the power cord from the AC line outlet, put a dust cover over it, and store the unit in a place meeting the following conditions.

- (1) Free of corrosive gas, dust and vibration
- (2) Environment temperature of -5 to 45°C,  
80% RH or less(non-condensating)

- 2) Transportation

When the unit is transported, avoid shock and vibration.

For long distance transportation, place the unit in a shock absorbing carton box with a HANDLE WITH CARE label to prevent rough handling.

- 3) Abandon

To abandon an old unit, observe the rules of your local government.

# 11. EXTERNAL APPEARANCE

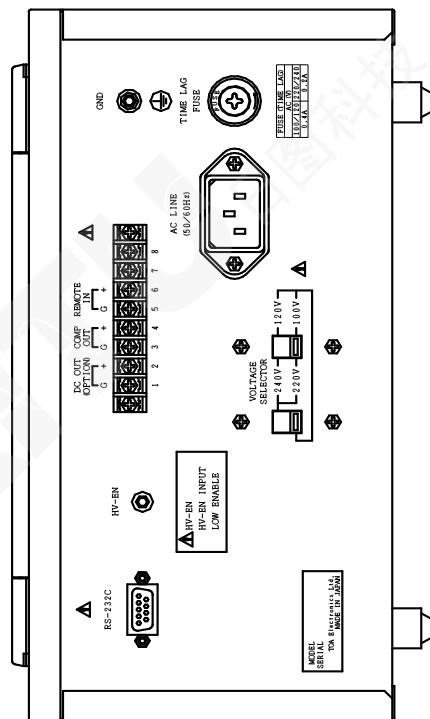
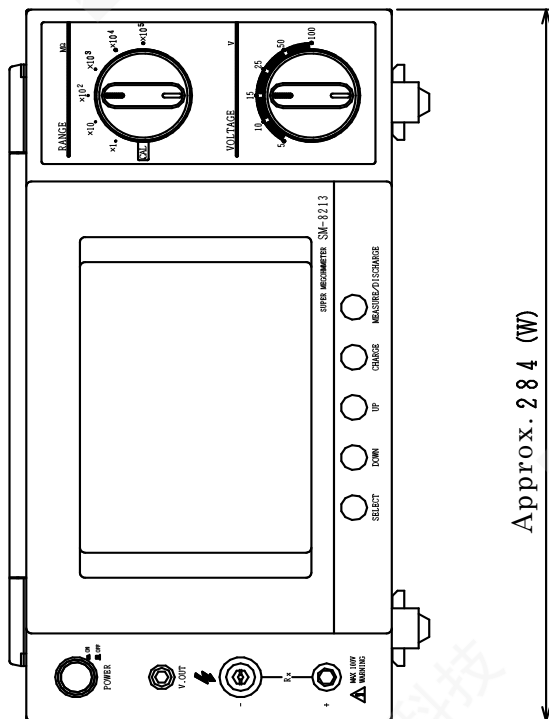
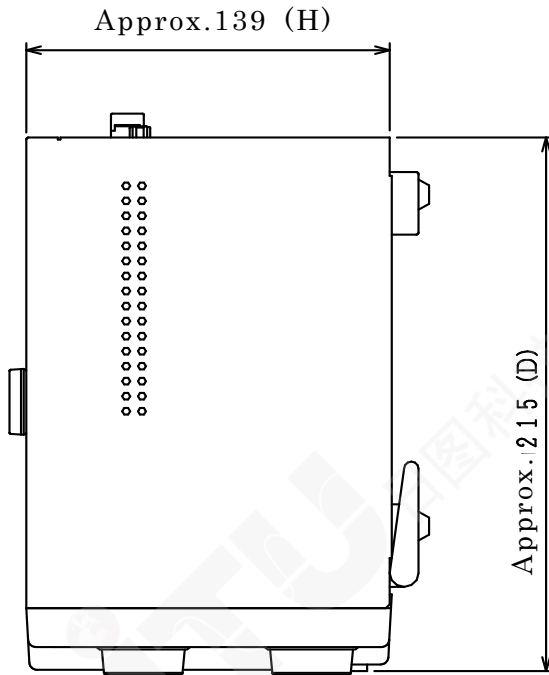

Unit: mm

# Warranty Certificate

# HIOKI

Model	Serial number	Warranty period One (1) year from date of purchase ( ___ / ___ )
-------	---------------	---

Customer name: \_\_\_\_\_  
Customer address: \_\_\_\_\_

## Important

- Please retain this warranty certificate. Duplicates cannot be reissued.
- Complete the certificate with the model number, serial number, and date of purchase, along with your name and address. The personal information you provide on this form will only be used to provide repair service and information about Hioki products and services.

This document certifies that the product has been inspected and verified to conform to Hioki's standards. Please contact the place of purchase in the event of a malfunction and provide this document, in which case Hioki will repair or replace the product subject to the warranty terms described below.

## Warranty terms

1. The product is guaranteed to operate properly during the warranty period (one [1] year from the date of purchase).  
If the date of purchase is unknown, the warranty period is defined as one (1) year from the date (month and year) of manufacture (as indicated by the first four digits of the serial number in YYMM format).
2. If the product came with an AC adapter, the adapter is warranted for one (1) year from the date of purchase.
3. The accuracy of measured values and other data generated by the product is guaranteed as described in the product specifications.
4. In the event that the product or AC adapter malfunctions during its respective warranty period due to a defect of workmanship or materials, Hioki will repair or replace the product or AC adapter free of charge.
5. The following malfunctions and issues are not covered by the warranty and as such are not subject to free repair or replacement:
  - 1. Malfunctions or damage of consumables, parts with a defined service life, etc.
  - 2. Malfunctions or damage of connectors, cables, etc.
  - 3. Malfunctions or damage caused by shipment, dropping, relocation, etc., after purchase of the product
  - 4. Malfunctions or damage caused by inappropriate handling that violates information found in the instruction manual or on precautionary labeling on the product itself
  - 5. Malfunctions or damage caused by a failure to perform maintenance or inspections as required by law or recommended in the instruction manual
  - 6. Malfunctions or damage caused by fire, storms or flooding, earthquakes, lightning, power anomalies (involving voltage, frequency, etc.), war or unrest, contamination with radiation, or other acts of God
  - 7. Damage that is limited to the product's appearance (cosmetic blemishes, deformation of enclosure shape, fading of color, etc.)
  - 8. Other malfunctions or damage for which Hioki is not responsible
6. The warranty will be considered invalidated in the following circumstances, in which case Hioki will be unable to perform service such as repair or calibration:
  - 1. If the product has been repaired or modified by a company, entity, or individual other than Hioki
  - 2. If the product has been embedded in another piece of equipment for use in a special application (aerospace, nuclear power, medical use, vehicle control, etc.) without Hioki's having received prior notice
7. If you experience a loss caused by use of the product and Hioki determines that it is responsible for the underlying issue, Hioki will provide compensation in an amount not to exceed the purchase price, with the following exceptions:
  - 1. Secondary damage arising from damage to a measured device or component that was caused by use of the product
  - 2. Damage arising from measurement results provided by the product
  - 3. Damage to a device other than the product that was sustained when connecting the device to the product (including via network connections)
8. Hioki reserves the right to decline to perform repair, calibration, or other service for products for which a certain amount of time has passed since their manufacture, products whose parts have been discontinued, and products that cannot be repaired due to unforeseen circumstances.



日图抖音号



日图公众号

### 深圳总部

深圳市南山区留仙大道南山云谷创新产业园二期 6 栋一楼东座  
电话：0755-83680722(8 线)

### 上海分公司

上海市闵行区中春路 8633 弄万科七宝国际 26 幢 701 室  
电话：021-33888891/3/5  
手机：13564654980

### 广州分公司

广州市科学城科学大道中 97 号科汇金谷 J 栋东座 808 室  
电话：020-31604020  
手机：18027340836

### 西安分公司

陕西省西安市雁塔区长安中路南飞鸿广场 3 号楼 1813 室  
手机：15529365365

### 杭州分公司

浙江省杭州市萧山区盈丰街道鸿宁路 1819 号左右世界 1 幢 1 单元 702-3  
电话：0571-86856181  
手机：18668225058

### 重庆分公司

重庆市观音桥茂业东方时代大厦 35 楼 3509 室  
电话：023-67904187  
手机：13896060852

### 苏州分公司

苏州苏州工业园区科营路 2 号中新生态大厦 10 楼 1010 室  
电话：0512-62515781、0512-62515784  
手机：15895400640

### 香港分公司

香港新界元朗屏厦厦村厦村路 DD125 段 1215-1217lot  
电话：+852-24932683

## 深圳市日图科技有限公司

SHENZHEN RITU SCIENCE TECHNOLOGY CO.,LTD

www.rituchina.com

400-616-5217

广东省深圳市南山区留仙大道南山云谷创新产业园二期 6 栋一楼东座

① 如需所有最新配套资料，请立即与日图科技各地分公司联系。